

MICROPROGRAM SEQUENCER

MICROPROGRAM SEQUENCER

- The basic component of microprogrammed control unit are the control memory and circuit that selects the next address.
- The address selection part is called as microprogram sequencer.
- The purpose of microprogram sequencer is to give address to control memory, so that microinstruction may be read and executed.
- The following diagram shows the interaction between sequencer and the memory attached to it.

Microprogram Sequencer

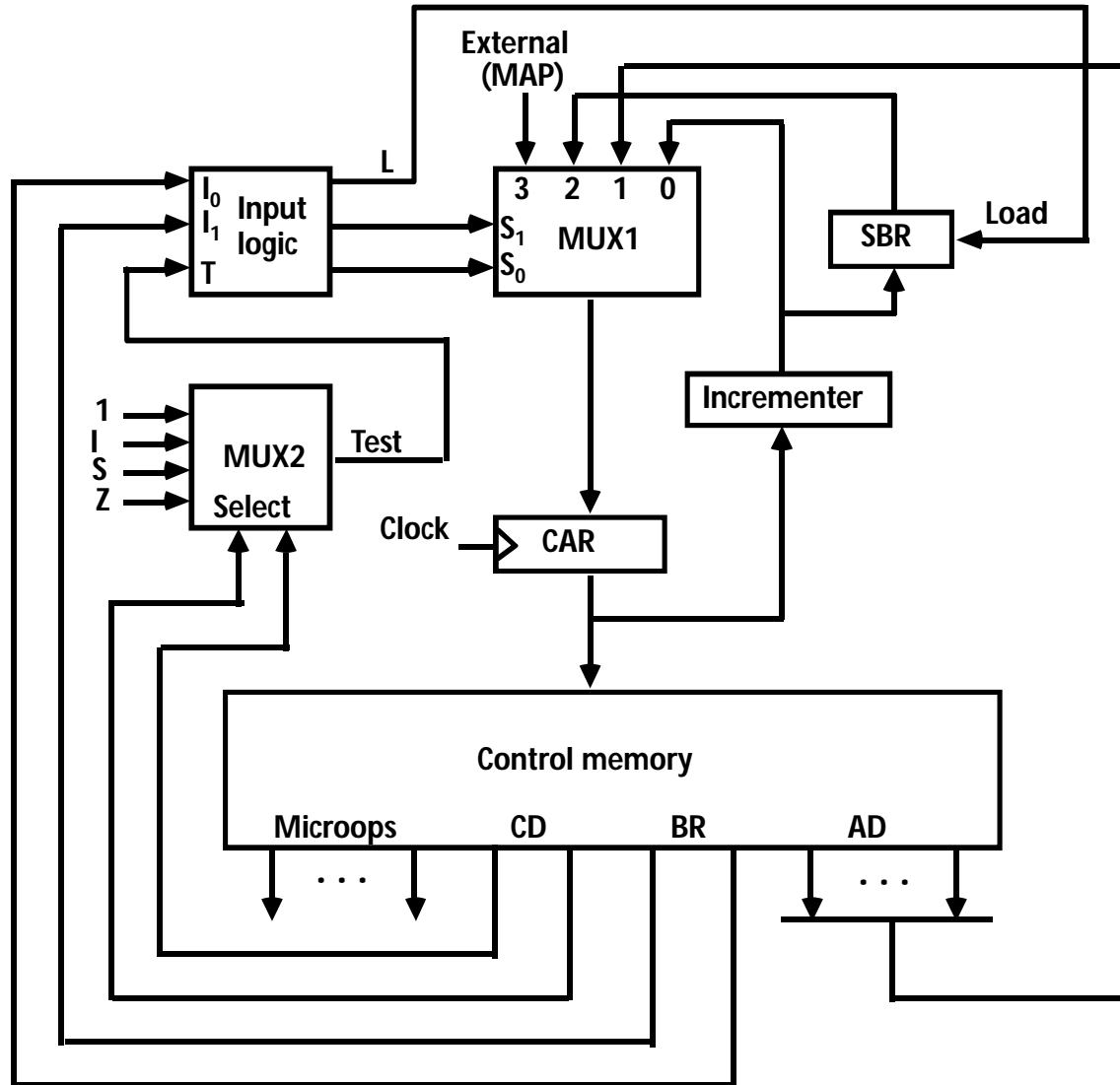

MICROPROGRAM SEQUENCER

- There are two multiplexer in the circuit. The first multiplexer selects an address from one of four sources and routes it into CAR.
- The second multiplexer test the value of a selected status bit and the result of the test is applied to an i/p logic circuit.
- The o/p from CAR provides the address to the control memory.
- The content of CAR is incremented and applied to the multiplexer's first i/p and to the subroutine register SBR.

MICROPROGRAM SEQUENCER

- The other 3 i/p's to the multiplexer comes from the address field of present microinstruction, o/p of SBR and from the external source that maps the instruction.
- The CD field of microinstruction selects one of the status bit in the second multiplexer.
- If the bit selected is equal to 1, the T(test) variable is equal to 1, otherwise it is 0.
- The T value together with the two bits from BR field go to i/p logic circuit.
- The i/p logic circuit will determine the type of operation that is available in the unit.

MICROPROGRAM SEQUENCER

- The i/p logic circuit has 3 i/p's I0, I1 and T and 3 o/p's S0, S1 and L (Load)
- Variables S0 and S1 selects one of the source address for CAR. Variable L enable the load i/p of SBR.
- The binary value of 2 selection variable determine the path of multiplexer.
- Ex: S1S0=10 Multiplexer i/p 2 is selected and establish a transfer path from SBR to CAR.