

**SREENIVASA INSTITUTE OF TECHNOLOGY
AND MANAGEMENT STUDIES**

(AUTONOMOUS)

DEPARTMENT OF MECHANICAL ENGINEERING

COURSE MATERIAL

Subject Name	Unconventional Machining Processes
Subject Code	23MEC364T
Semester	VI Semester
Academic Year	2025-26
Regulation	R23

Unit-I

Mechanical Energy Based Processes

CHAPTER - 1**INTRODUCTION AND MECHANICAL
ENERGY BASED PROCESSES**

Syllabus : Unconventional machining Process - Need - classification - merits, demerits and applications. Abrasive Jet Machining - Water Jet Machining - Abrasive Water Jet Machining - Ultrasonic Machining. (AJM, WJM, AWJM and USM). Working Principles - equipment used - Process parameters - MRR- Applications.

Section No.	Topic Name	Page No.
1.1	Introduction	1 - 2
1.2	Comparison between Conventional and Unconventional Machining Processes	1 - 4
1.3	Classification of Advanced Machining Processes	1 - 5
1.4	Classification of Unconventional Machining Process	1 - 8
1.5	Physical Parameters of the Process	1 - 11
1.6	Hybrid Process	1 - 15
1.7	General Characteristics of Unconventional Machining Process	1 - 16
1.8	Comparison of Various Unconventional Machining Process	1 - 18
1.9	Mechanical Energy Based Process	1 - 19
1.10	Abrasive Jet Machining (AJM)	1 - 19
1.11	Abrasive Water Jet Machining (AWJM)	1 - 30
1.12	Water Jet Machining (WJM)	1 - 40
1.13	Ultra-Sonic Machining	1 - 48
1.14	Two Marks Questions with Answers (Part - A)	1 - 64
1.15	Long Answered Questions (Part - B)	1 - 68
1.16	Multiple Choice Questions with Answers	1 - 70

1.1 Introduction

- The main work of an engineer and scientist is the development of newer methods.
- The main ideas behind such works are :
 - Economic considerations.
 - Replacement of old manufacturing methods by faster ones and more efficient ones.
 - To get high accuracy and high surface finish.
 - Use low cost material instead of costlier ones.
 - Developing new methods of machining to machine hard materials which cannot be machined by conventional or normal methods, like tungsten, uranium, tantalum stainless steel, etc.
- The use of such costly and hard to machine materials is common in tool design industries, aircraft industries, space research equipments, power plants, ammunition industries, etc.
- To meet the requirements of these industries newer methods are developed by the engineers and scientists.
- These machining methods are called as “**Non-conventional or Un-conventional or Non-traditional or Modern methods of machining**”.
- The common parameters to be taken into consideration for selecting a particular process are as follows :
 - Physical properties of work material.
 - Type of operation to be performed like cutting, hole making, etc.
 - Shape and size required to be produced.
 - Process capabilities i.e. expected tolerance, power requirement, Metal Removal Rate (MRR), surface finish, etc.
 - Economy of the process.
 - Physical properties of workpiece material.

Limitations of conventional manufacturing process

- i) Conventional manufacturing process are difficult to machine the harder or newly developed materials like carbides, ceramics, High Strength Temperature Resistance (HSTR) alloys etc.,
- ii) The surface finish level is not quite high.
- iii) High tolerance or close tolerance cannot be achieved.
- iv) Difficult to obtain complex shapes.

- v) Automated data transmission is not possible.
- vi) Mass production at high production rate with high accuracy is not possible.
- vii) The generation of shallow holes, non-circular micro sized holes are not possible.
- viii) High wastage of material.
- ix) The degree of accuracy and precision are not in best position.
- x) A large number of holes in a single workpiece with better quality is quite difficult.
- xi) Unconventional machining process not so effective on soft materials like aluminium because accuracy cannot be maintained due to more material removal rate.

1.1.1 Characteristics of Non Conventional Processes

Non Traditional Machining (NTM) processes are characterized as follows :

- Material removal may occur with chip formation or even no chip formation may take place. For example in AJM, chips are of microscopic size and in case of Electrochemical machining material removal occurs due to electrochemical dissolution at atomic level
- In NTM, there may not be a physical tool present. For example in laser jet machining, machining is carried out by laser beam. However in Electrochemical Machining there is a physical tool that is very much required for machining
- In NTM, the tool need not be harder than the work piece material. For example, in EDM, copper is used as the tool material to machine hardened steels.
- Mostly NTM processes do not necessarily use mechanical energy to provide material removal. They use different energy domains to provide machining. For example, in USM, AJM, WJM mechanical energy is used to machine material, whereas in ECM electrochemical dissolution constitutes material removal. Comparatively high initial cost.

1.1.2 Need for Development of Un-Conventional Processes

- The strength of steel alloys has increased five folds due to continuous R and D effort.
- In aero-space requirement of high strength at elevated temperature with light weight led to development and use of hard titanium alloys, nimonic alloys, and other HSTR alloys. .
- The ultimate tensile strength has been improved by as much as 20 times.
- Development of cutting tools which has hardness of 80 to 85 HRC which cannot be machined economically in conventional methods led to development of non –traditional machining methods.

1. Technologically advanced industries like aerospace, nuclear power, ,wafer fabrication, automobiles has ever increasing use of High –strength temperature resistant (HSTR) alloys (having high strength to weight ratio) and other difficult to machine materials like titanium, SST,nimonics, ceramics and semiconductors. It is no longer possible to use conventional process to machine these alloys.
2. Production and processing parts of complicated shapes (in HSTR and other hard to machine alloys) is difficult , time consuming an uneconomical by conventional methods of machining.
3. Innovative geometric design of products and components made of new exotic materials with desired tolerance , surface finish cannot be produced economically by conventional machining.
4. The following examples are provided where NTM processes are preferred over the conventional machining process :
 - Intricate shaped blind hole – e.g. square hole of 15 mm × 15 mm with a depth of 30 mm with a tolerance of ± 100 microns.
 - Difficult to machine material – e.g. Inconel, ti-alloys or carbides, ceramics, composites , HSTR alloys, satellites etc.,
 - Low stress grinding – Electrochemical grinding is preferred as compared to conventional grinding.
 - Deep hole with small hole diameter – e.g. ϕ 1.5 mm hole with $l/d = 20$
 - Machining of composites.

Definition :

A machining process is called *non-traditional* if its material removal mechanism is basically different than those in the traditional processes, i.e. a different form of energy (other than the excessive forces exercised by a tool, which is in physical contact with the work piece) is applied to remove the excess material from the work surface, or to separate the workpiece into smaller parts.

1.2 Comparison between Conventional and Unconventional Machining Processes

S.No	Conventional Process	Un Conventional Process
1.	The cutting tool and work piece are always in physical contact with relative motion with each other, which results in friction and tool wear.	There is no physical contact between the tool and work piece, In some nontraditional process tool wear exists.

2.	Material removal rate is limited by mechanical properties of work material.	NTM can machine difficult to cut and hard to cut materials like titanium, ceramics, nimonics, SST, composites, semiconducting materials.
3.	Relative motion between the tool and work is typically rotary or reciprocating. Thus the shape of work is limited to circular or flat shapes. In spite of CNC systems, production of 3D surfaces is still a difficult task.	Many NTM are capable of producing complex 3D shapes and cavities.
4.	Machining of small cavities , slits , blind holes or through holes are difficult.	Machining of small cavities, slits and Production of non-circular, micro sized, large aspect ratio, shall entry angle holes are easy using NTM.
5.	Use relative simple and inexpensive machinery and readily available cutting tools.	Nontraditional processes requires expensive tools and equipment as well as skilled labour, which increase the production cost significantly.
6.	Capital cost and maintenance cost is low.	Capital cost and maintenance cost is high.
7.	Traditional processes are well established and physics of process is well understood.	Mechanics of Material removal of Some of NTM process are still under research.
8.	Conventional process mostly uses mechanical energy.	Most NTM uses energy in direct form For example : laser, Electron beam in its direct forms are used in LBM and EBM respectively.
9.	Surface finish and tolerances are limited by machining inaccuracies.	High surface finish(up to 0.1 micron) and tolerances (25 Microns)can be achieved.
10.	High metal removal rate.	Low material removal rate.

1.3 Classification of Advanced Machining Processes

The different non-conventional machining methods are generally classified using the following criteria :

- (1) **According to the type of energy used** : Mechanical, electro-chemical or electrothermal, chemical, etc.
- (2) **According to the energy source** : Pneumatic or hydraulic pressure, mechanical pressure, high current or voltage, etc.
- (3) **According to the medium for energy transfer** : High velocity particles, physical contact, electrolyte, hot gases, electrons, radiation, etc.
- (4) **According to the metal removal mechanism** : Erosion, spark erosion, shear, vaporisation, etc.

1.3.1 Process Selection

The common parameters to be taken into consideration for selecting a particular process are as follows :

(i) Physical parameters of unconventional machining methods

Table 1.1 : Physical parameters in non-conventional machining methods

Parameters	Unconventional machining methods						
	EDM	EBM	PAM	LBM	USM	AJM	ECM
Voltage (Vts)	100 to 300	150×10^3	100	4.5×10^3	220	220	10 to 30
Current (Amp)	50	0.001	500	2	12	1	10,000
Power (kW)	2.7	0.15	50	-	2.4	0.22	100
Gap (mm)	0.025	100	7.5	150	0.25	0.75	0.2
Medium	Dielectric fluid	Vacuum	Hydrogen or argon	Air	Abrasive in water or paraffin	Abrasive in gas	Electrolyte

(ii) Shape and size required to be produced

- The different non-conventional machining methods have some special shape producing capability as follows :
 - Standard hole drilling : EDM and USM
 - Fine hole drilling and contour machining : ECM
 - Clean, rapid cuts and profiles : PAM
 - Micro-machining and drilling : LBM and EBM

(iii) Process capability

- Out of all the non-conventional machining methods, EDM has the lowest specific power requirement and it can achieve sufficient accuracy whereas ECM has the highest MRR (Metal Removal Rate).
- USM and AJM have low MRR and combined with tool wear whereas LBM and EBM have high penetration rates with low MRR.

(iv) Process economy

- The process economy of various non-conventional machining methods is given in the following Table 1.2.

Table 1.2 : Process economy

Process	Capital cost	Power requirement	Efficiency
EDM	Medium	Low	High
EBM	High	Low	Very high
PAM	Very low	Very low	Very low
LBM	Medium	Very Low	Very high
USM	Low	Low	High
AJM	Very low	Low	High
ECM	Very high	Medium	Low
Conventional method	Low	Low	Very low

(v) Physical properties of workpiece material

(vi) Type of operation to be performed

1.3.2 Commonly Used Advanced Machining Processes

- (1) Electro-Discharge Machining (EDM)
- (2) Wire-cut Electro-Discharge Machining (W-EDM)
- (3) Electron Beam Machining (EBM)
- (4) Plasma Arc Machining (PAM)
- (5) Laser Beam Machining (LBM)
- (6) Ultra Sonic Machining (USM)
- (7) Abrasive Jet Machining (AJM)
- (8) Electro-Chemical Machining (ECM)
- (9) Chemical Machining (CM)
- (10) Electro-Chemical Grinding (ECG)
- (11) Water-Jet Machining (WJM)
- (12) Ion-Beam Machining (IBM)

1.4 Classification of Unconventional Machining Process

Unconventional machining process are classified as follows :

a) Based on the type of energy required to shape the material

- i. Thermal energy method
- ii. Electrical energy method
- iii. Electro Chemical energy method
- iv. Chemical energy method
- v. Mechanical energy method.

Table 1.3 : Classification of non-conventional processes

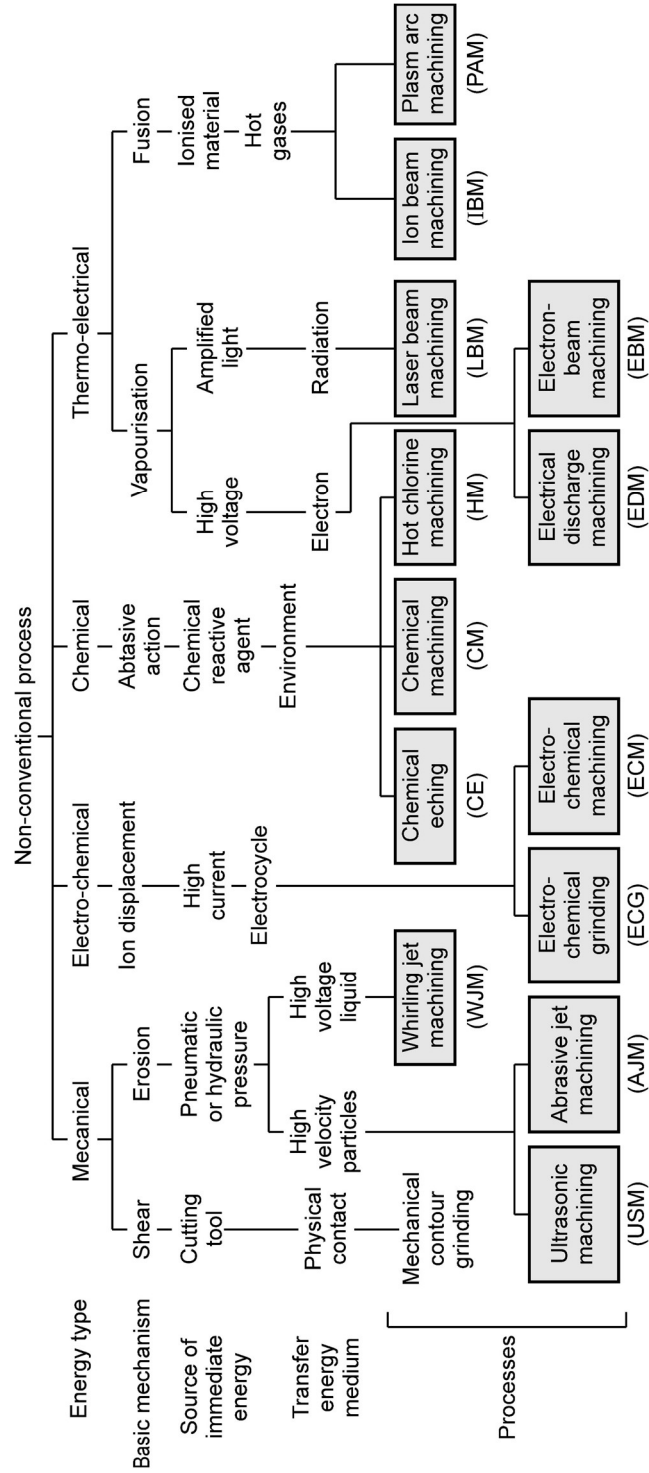

b) Based on the mechanism involved in the process

- i. Erosion
- ii. Ionic dissolution
- iii. Vaporisation

c) Source of energy required for material removal

- i. Hydrostatic pressure
- ii. High current density
- iii. High voltage
- iv. Ionised material

d) Medium of transfer of energies

- i. High voltage particles
- ii. Electrolyte
- iii. Electron
- iv. Hot gases

Abbreviations Used :

1. AJM - Abrasive Jet Machining
2. USM - Ultrasonic Machining
3. WJM - Water Jet Machining
4. AWJM - Abrasive Water Jet Machining
5. ECM - Electro Chemical Machining
6. ECG - Electro Chemical Grinding
7. EJD - Electro Jet Drilling
8. EDM - Electro Discharge Machining
9. LJM - Laser Jet Machining
10. EBM - Electron beam Machining
11. PAM - Plasma Arc Machining
12. CHM - Chemical Milling
13. PCM - Photo Chemical Milling

1.4.1 Selection of Process

The correct selection of the non-traditional machining methods must be based on the following aspects.

- i) Physical parameters of the process
- ii) Shape to be machined
- iii) Process capability
- iv) Economics of the processes

1.5 Physical Parameters of the Process

EBM and LBM require high voltages and require careful handling of equipment. EDM and USM require medium power. EBM can be used in vacuum and PAM uses oxygen and hydrogen gas.

Parameters	Non Traditional Process							
	USM	AJM	CHM	ECM	EDM	EBM	LBM	PAM
Potential (Volts)	220	220	-	10-30	100-300	150 kV	4.5 kV	100
Current (Amps)	12	1	-	10000	50	0.001	2	500
Power (KW)	2.4	0.22	-	100	2.70	0.15	-	50
Gap (mm)	0.25	0.75	-	0.20	0.025	100	150	7.5
Medium	Abrasives In water	Abrasive In gas	Liquid chemical	Electrolyte	Dielectric Oil	Vacuum	Air	Argon H₂/O₂

1.5.1 Shapes Cutting Capability

The different shapes can be machined by NTM. EBM and LBM are used for micro drilling and cutting. USM and EDM are useful for cavity sinking and standard hole drilling. ECM is useful for fine hole drilling and contour machining. PAM can be used for cutting and AJM is useful for shallow pocketing.

Application	Process well suited
Producing micro holes	LBM
Producing small holes	EBM
For deep holes (L/D >20) and contour machining	ECM
For shallow holes	USM and EDM
For precision through cavities in workpieces	USM and EDM
For Honing	ECM
For etching small portions	ECM and EDM
For grinding	AJM and EDM
For deburring	USM and AJM
For threading	EDM
For clean, rapid cuts and profiles	PAM
For shallow pocketing	AJM

Capability to shape

Process	Capability to									
	Contouring a surface	Micro Drill	Drill		Cavity sinking		Pocketing Operation		Through cutting	
			L/D <20	L/D >20	Accurate Operation	Standard Operation	Shallow Pocketing	Deep pocketing	Shallow cutting	Deep cutting
USM	P	-	G	P	G	G	P	P	P	-
AJM	-	-	F	P	P	F	-	-	G	-
ECM	G	-	G	G	F	G	G	G	G	G
CHM	-	F	-	-	P	F	G	P	G	-
EDM	F	-	G	F	G	G	G	G	P	-
EBM	-	F	F	P	P	P	-	-	G	F
LBM	-	G	F	P	P	P	-	-	G	F
PAM	-	-	F	-	P	P	-	-	G	G

P - Poor , F- Fair, G- Good

1.5.2 Process Capability

The process capability of NTM which achieves higher accuracy has the lowest specific power requirement. ECM can machine faster and has a low thermal surface damage depth. USM and AJM have very material removal rates combined with high tool wear and are used nonmetal cutting. LBM and EBM are, due to their high penetration depth can be used for micro drilling, sheet cutting and welding. CHM is used for manufacture of PCM and other shallow components.

Process	Material Removal rate	Surface finish	Accuracy		Specific power	
			L/D <20	L/D >20	Accurate Operation	Standard Operation
USM	P	-	G	P	G	G
AJM	-	-	F	P	P	F
ECM	G	-	G	G	F	G
CHM	-	F	-	-	P	F
EDM	F	-	G	F	G	G
EBM	-	F	F	P	P	P
LBM	-	G	F	P	P	P
PAM	-	-	F	-	P	P

1.5.3 Applicability to Material

Process	Metals and alloys					Non-Metals		
	Aluminum	Steel	Super Alloys	Titanium	Refractory Material	Ceramics	Plastics	Glass
USM	P	F	P	F	G	G	F	G
AJM	F	F	G	F	G	G	F	G
ECM	F	G	G	F	F	-	-	-
CHM	G	G	F	F	P	P	P	P
EDM	F	G	G	G	G	-	-	-
EBM	F	F	F	F	G	G	F	F

LBM	F	F	F	F	P	G	F	F
PAM	G	G	G	F	P	-	P	-

P - Poor , F- Fair, G- Good

1.5.4 Machining Characteristics

Process	A	B	C	D	E
USM	300	7.5	0.2-0.5	25	2,400
AJM	0.8	50	0.5-1.2	2.5	250
ECM	15,000	50	0.1-2.5	5	1 Lakh
CHM	15	50	0.5-2.5	5	-
EDM	800	15	0.2-1.2	125	2700
EBM	1.6	25	0.5-2.5	250	150(Avg) 2 (Peak)
LBM	0.1	25	0.5-1.2	125	2 (Avg.) 200 (Peak)
PAM	75,000	125	Rough	500	50,000

3

A – Metal Removal rate obtained (in mm³/min)

B – Tolerance maintained (in micron)

C – Surface finish obtained (in micron)

D – Depth of surface damaged (in micron)

E – Power required for machining (in watts)

1.5.5 Effects on Equipment and Cooling

Process	Tool wear ratio	Machining medium contamination	Safety	Toxity
USM	10	B	A	A
AJM	-	B	B	B
ECM	-	C	B	A

CHM	-	C	B	A
EDM	6.6	B	B	B
EBM	-	B	B	A
LBM	-	A	B	A
PAM	-	A	A	A

A - No Problem , B - Normal Problem, C - Critical Problem

$$\text{Tool wear ratio} = \frac{\text{Volume of work material removed}}{\text{Volume of tool electrode removed}}$$

1.6 Hybrid Process

- To increase the capabilities of the machining processes, two or more than two machining processes are combined to take advantage of each and every processes.
- For example : A conventional grinding produces good surface finish and low tolerances but the components are associated with burrs, heat affected zone and residual stresses. But, electrochemically machined components do not have such defects. Hence, a hybrid process known as electrochemically grinding (ECG) has been developed.
- Similarly, other hybrid processes like electrochemical spark machining, electrochemical arc machining, electro-discharge abrasive, etc. have been developed.
- This chapter includes the following processes :

- i) Abrasive Flow Finishing (AFF)
- ii) Magnetic Abrasive Finishing (MAF)
- iii) Abrasive Water Jet Machining (AWJM)
- iv) Wire Electric Discharge Machining (W - EDM)
- v) Electrochemical Grinding (ECG)
- vi) Electrochemical De-burring (ECD)
- vii) Shaped Tube Electrolytic Machining (STEM)
- viii) Electrolyte Jet Machining (EJM)
- ix) Electrolytic in-Process Dressing (ELPD)
- x) Ultrasonic assisted EDM (U - EDM)
- xi) Rotary EDM
- xii) Electrochemical Discharge Machining (ECDM)
- xiii) Laser surfac

1.7 General Characteristics of Unconventional Machining Process

Process	Characteristics	Process Parameters, Typical MRR or cutting speed
Chemical Machining (CHM)	<ul style="list-style-type: none"> ➤ Shallow removal (upto 12 mm) on large flat or curved surfaces; ➤ Blanking of thin sheets; ➤ Low tooling and equipment cost; ➤ Suitable for low production runs. 	0.025 - 0.1 mm/min
Electrochemical Machining (ECM)	<ul style="list-style-type: none"> ➤ Complex shapes with deep cavities; ➤ High MRR; ➤ Expensive tooling and equipment; ➤ High power consumption; ➤ Medium to high production quantity. 	Voltage – 5 to 25 ² DC- 1.5 to 8 A/mm ² 2.5 – 12 mm/min Depending on current density
Electrochemical Grinding (ECG)	<ul style="list-style-type: none"> ➤ Cutting off and sharpening hard materials such as tungsten carbide tools; ➤ Also used as a honing process; ➤ Higher material removal rate than grinding. 	A: 1-3 A/mm ² Typically 1500 mm ³ / min per 1000 A
Electrical Discharge Machining (EDM)	<ul style="list-style-type: none"> ➤ Shaping and cutting complex parts made of hard materials; ➤ Some surface damage may result; ➤ Also used for cutting and grinding; ➤ Versatile expensive tooling and equipment; 	V: 50-380 A : 0.1-500 Typically ³ 300 mm ³ /min.
Wire EDM	<ul style="list-style-type: none"> ➤ Contour cutting of flat or curved surfaces; ➤ Expensive equipment. 	Varies with workpiece material and its thickness.

<p>Laser Beam Machining (LBM)</p>	<ul style="list-style-type: none"> ➤ Cutting and hole making in thin materials ➤ Heat Affected Zone (HAZ) ➤ Does not require vacuum ➤ Expensive equipment ➤ Consumes much energy ➤ Extreme caution required in use 	<p>0.5 – 7.5 m/min</p>
<p>Abrasive Water Jet Machining (AWJM)</p>	<ul style="list-style-type: none"> ➤ Single and multilayer cutting of metallic and non-metallic materials 	<p>Upto 7.5 m/min.</p>
<p>Electron Beam Machining (EBM)</p>	<ul style="list-style-type: none"> ➤ Cutting and hole making on thin materials ➤ Very small holes and slots. ➤ HAZ ➤ Requires vacuum ➤ Expensive equipment 	<p>1-2 mm³ /min.</p>
<p>Water Jet Machining (WJM)</p>	<ul style="list-style-type: none"> ➤ Cutting all types of non-metallic materials to 25 mm. and greater in thickness. ➤ Suitable for contour cutting of flexible materials ➤ No thermal damage ➤ Environmentally safe process. 	<p>Varies considerably with workpiece material.</p>
<p>Abrasive Jet Machining (AJM)</p>	<ul style="list-style-type: none"> ➤ Cutting, slotting, deburring, flash removal, etching and cleaning of metallic and non-metallic materials. ➤ Tends to round off sharp edges ➤ Some hazard because of airborne particulates. (Airborne particulate matter, which includes dust, dirt, soot, smoke, and liquid droplets emitted into the air, is small enough to be suspended in the atmosphere) 	<p>Varies considerably with workpiece material.</p>

1.8 Comparison of Various Unconventional Machining Process

S.No	Process parameters	EDM	ECM	EBM	LBM	PAM	USM	AJM	WJM
1	Metal Removal Technique	By using powerful electric spark	Based on faraday's Laws of electrolysis	By using high velocity beam of electrons	By using high intensity of laser beam	Heating, melting and vaporizing by using plasma	Slurry of small abrasive particles is forced against workpiece by means of vibrating tool	By using high stream of abrasive particles mixed with air	By using high velocity of water jet
2	Work material	Electrically conductive metals and alloys	Difficult to machine Electrically conductive materials	All materials	All materials except those having high thermal conductivity and high reflectivity	All materials which conduct electricity	Tungsten Carbide, Glass, Quartz, ceramics, etc,	Hard and brittle materials like glass, quartz, ceramics, etc	Soft and non-metallic materials like wood, plastic, paper-board etc
3	Tool material	Copper, yellow, alloy of zinc, copper, tungsten etc.,	Copper, brass, titanium, copper tungsten, stainless steel etc.,	Electron Beam	Laser Beam	Plasma	Low carbon steel, stainless steels	Abrasives like aluminium oxide, silicon carbide, glass powder etc.,	Water jet
4	Metal removal (mm ³ / sec)	15 to 80	27	15 to 40	0.10	2500	14	0.014	0.6
5	Surface finish in µm	0.25	0.2 to 0.8	0.4 to 6	0.4 to 6	Rough	0.2 to 0.7	0.5 to 1.2	0.5 to 0.8
6	Power requirement	Low	Medium	Low	Very low	Very low	Low	Low	High
7	Capital cost	Medium	High	High	High	Low	High	Very low	High
8	Efficiency	High	Low	Very high	Very high	Very low	High	High	High
9	Applications	Production of complicated and irregular shaped profiles and re sharpening of cutting tools	Machining hard materials and complex shaped parts	Micro machining operations on thin materials like drilling, slotting, scribing etc.,	Drilling micro holes (upto 250 µm) and cutting very narrow slots	Profile cutting of stainless steel, monel and super alloy plates	Efficiently applied to machine glass, ceramics, tungsten etc.,	Intricate hole shapes in hard and brittle materials	Machining non-metallic materials
10	Limitations	Not suitable for non-conducting materials	Not suitable for non-conducting materials	Not suitable for large work pieces, necessity of vacuum	Taper of 0.05 mm when work thickness is more than 0.25 mm	Low accuracy	Low metal removal rate, high rate of tool wear	Low MRR, low accuracy	Difficult to machine hard materials

1.9 Mechanical Energy Based Process

The mechanical energy based processes are as follows :

- Abrasive Jet Machining
- Water Jet Machining
- Abrasive Water Jet Machining

1.10 Abrasive Jet Machining (AJM)

- AJM uses a stream of fine grained abrasives (of size 10 to 40 microns) mixed with air or some other carrier gas at high pressure.
- This stream is directed on the work surface by using a suitable nozzle.
- The velocity of carrier gas or air is upto 200 to 400 m/sec.
- Due to this high speed, impact on the work surface erosion takes place by abrasive particles and metal removes from the workpiece.
- AJM differs from the conventional sand blasting process in the way that the abrasive is much finer and the effective control over the process parameters and cutting action. This process is chiefly employed to cut hard and brittle materials which are thin, sensitive to heat and have a tendency to break away or chip off easily.

Construction

- Fig. 1.1 shows typical setup for Abrasive Jet Machining, which consists of a 'mixing chamber' in which fine grained abrasive particles are filled through a holding device like a 'hopper'.
- This mixing chamber vibrates (upto 50 cycles/sec) and amplitude of these vibrations controls the flow of abrasive particles. To control the amplitude of vibration, regulator is placed in the system.
- Compressed air or high pressure gas is supplied to the mixing chamber through a pipe line, which carries a pressure gauge to control its pressure.
- These particles mix in the stream of gas, travel via a hose and pass through a nozzle. This stream of mixture of gas and abrasive particles is called as **Abrasive Jet**.

Process

- In abrasive jet machining abrasive particles are made to impinge on work material at high velocity. Jet of abrasive particles is carried by carrier gas or air.
- The high velocity stream of abrasives is generated by converting pressure energy of carrier gas or air to its Kinetic energy and hence high velocity jet.

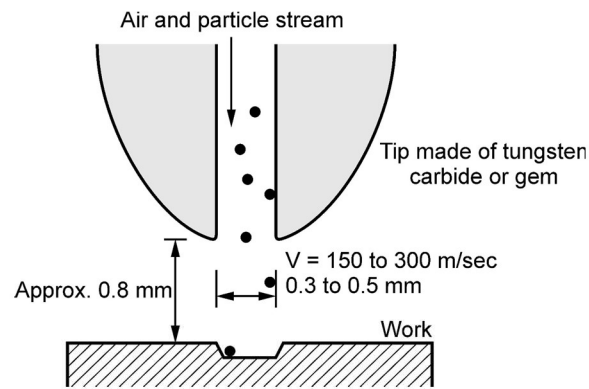

Fig. 1.1

- Nozzles direct abrasive jet in a controlled manner onto work material.
- The high velocity abrasive particles remove the material by micro-cutting action as well as brittle fracture of the work material.

Working

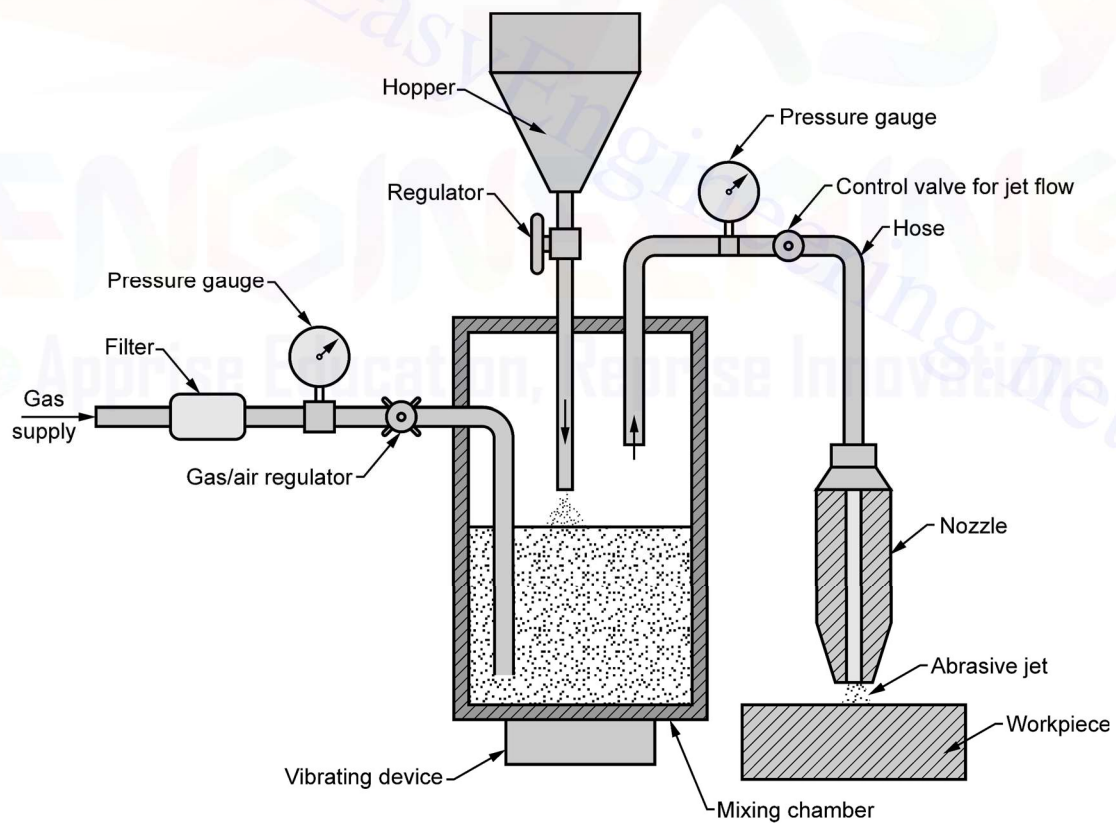

Fig. 1.2 Schematic diagram of AJM

- Through hopper, fine grained abrasive powder is filled in a mixing chamber.
- The gas or air is supplied under pressure into the chamber; the pressure of gas varies from 2 to 8 kg/cm².
- The gas is supplied through the pipeline which carries a pressure gauge and regulator to control the flow.
- This mixture of high pressure gas and compressed air is passed through a nozzle on the the surface of workpiece, and due to high speed mixture erosion is caused and metal removal takes place.

Equipment :

Abrasive jet machining consists of

- | | |
|--------------------------|--------------------|
| 1. Gas propulsion system | 2. Abrasive feeder |
| 3. Machining chamber | 4. AJM nozzle |
| 5. Abrasives | |

1. Gas Propulsion System

- It supplies clean and dry air. Air, nitrogen and carbon dioxide to propel the abrasive particles. Gas may be supplied either from a compressor or a cylinder.
- In case of a compressor, air filter cum drier should be used to avoid water or oil contamination of abrasive powder. Gas should be non-toxic, cheap, easily available.
- It should not excessively spread when discharged from nozzle into atmosphere.
- The propellant consumption is of order of 0.008 m³/min at a nozzle pressure of 5 bar and abrasive flow rate varies from 2 to 4 gm/min for fine machining and 10 to 20 gm/min for cutting operation.

2. Abrasive Feeder

- Required quantity of abrasive particles is supplied by abrasive feeder. The filleted propellant is fed into the mixing chamber where in abrasive particles are fed through a sieve.
- The sieve is made to vibrate at 50-60 Hz and mixing ratio is controlled by the amplitude of vibration of sieve.
- The particles are propelled by carrier gas to a mixing chamber.
- Air abrasive mixture moves further to nozzle. The nozzle imparts high velocity to mixture which is directed at work piece surface.

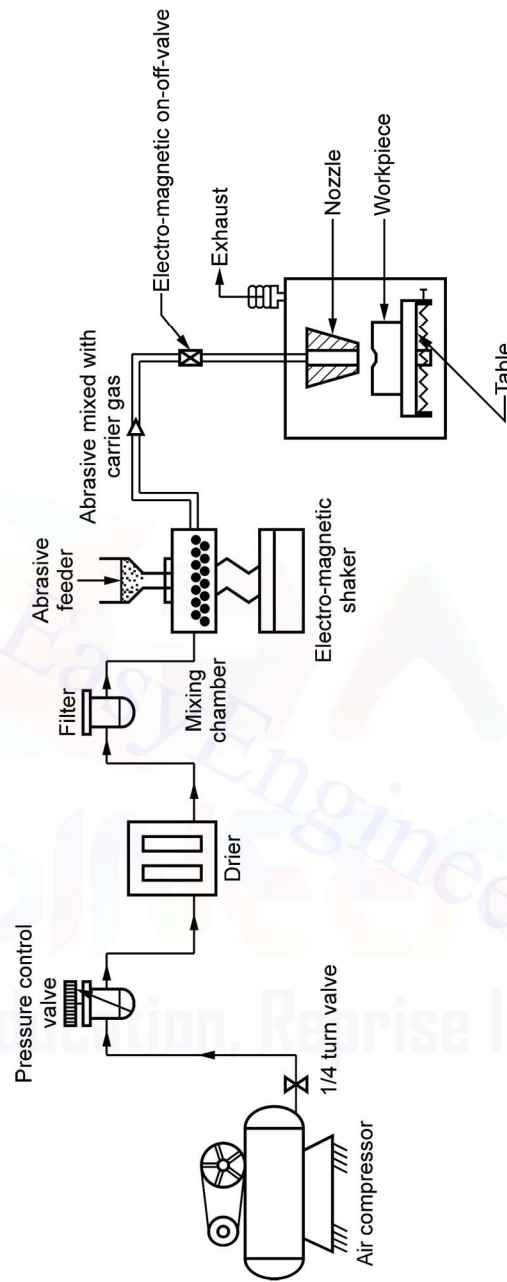

Fig. 1.3

3. Machining chamber

- It is well closed so that concentration of abrasive particles around the working chamber does not reach to the harmful limits. Machining chamber is equipped with vacuum dust collector.

- Special consideration should be given to dust collection system if the toxic material (like beryllium) are being machined.

4. AJM nozzle

- AJM nozzle is usually made of tungsten carbide or sapphire (usually life – 300 hours for sapphire, 20 to 30 hours for WC) which has resistance to wear.
- The nozzle is made of either circular or rectangular cross section and head can be head can be straight, or at a right angle.
- It is so designed that loss of pressure due to the bends, friction etc is minimum possible.
- With increase in wear of a nozzle, the divergence of jet stream increases resulting in more stray cutting and high inaccuracy.

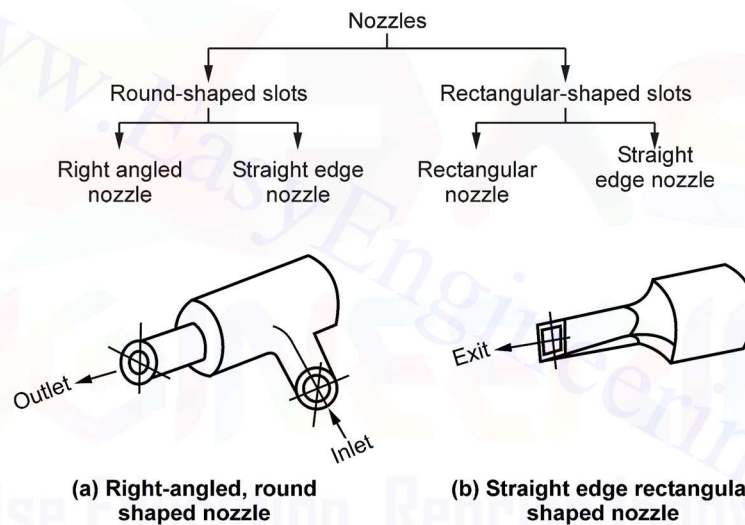

Fig. 1.4

Nozzle material	Round shape nozzle diameter, mm	Rectangular shape slot dimension, mm	Life of nozzle, hours
Tungstern carbide (WC)	0.2 to 1.0	0.075 × 0.5 to 0.15 × 2.5	12 to 30
Sapphire	0.2 to 0.8	—	300

5. Abrasives

- Aluminum oxide (Al_2O_3) Silicon carbide (SiC) Glass beads, crushed glass and sodium bicarbonate are some of abrasives used in AJM. Selection of abrasives depends on MRR , type of work material, machining accuracy.

Abrasives	Grain Sizes	Application
Aluminum oxide(Al_2O_3)	12, 20, 50 microns	Good for cleaning, cutting and deburring
Silicon carbide (SiC)	25,40 micron	Used for similar application but for hard material
Glass beads	0.635 to 1.27 mm	Gives matte finish
Dolomite	200 mesh	Etching and polishing
Sodium bi carbonate	27 micros	Cleaning, deburring and cutting of soft material Light finishing below 50 °C

1.10.1 Mechanism of Material Removal in AJM

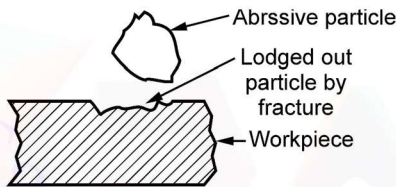

Fig. 1.5 Mechanism of metal removal in abrasive jet machining

When the abrasive particles impinge on the work piece or work surface at a high velocity, the impact of the particles causes brittle fracture at the places where the particles hit and the following gas or air varies away the dislodges small workpiece particles.(wear particles). The mathematical model of the material removal rate is based on the following assumptions.

1. The abrasive particles are considered to be rigid and spherical bodies of equal diameter to the average grit size.
2. The material removed is equal to the volume of indentation in the case of a ductile work material. It is equal to the chord length of indentation and is hemispherical in shape in the case of brittle material.

$$\text{MRR for brittle material} = 1.04 [MV^{3/2} / \rho^{1/4} H^{3/4}]$$

$$\text{MRR for ductile material} = 0.5 [MV^2 / H]$$

Where,

M = The abrasive mass flow rate

V = The impact velocity

ρ = The density of the particle

H = The material hardness of the work piece.

- From the equation, Velocity plays a dominant role compared to the mass flow rate on MRR. Under low velocity conditions ductile materials show lower MRR.

- For successful utilization of AJM process, it is necessary to analyze the following process criteria.

1. Material removal rate
2. Geometry and surface finish of work piece
3. Wear rate of the nozzle

However, process criteria are generally influenced by the process parameters as enumerated below :

- **Abrasives**

- a) Material – Al_2O_3 , SiC, glass beads, crushed glass, sodium bi carbonate
- b) shape – irregular/regular
- c) Size – 10 to 50 microns
- d) Mass flow – 2-20 gm/min

- **Carrier Gas**

- a) Composition – Air, CO_2 , N_2
- b) Density - 1.3 kg/m³
- c) Velocity - 500 to 700 m/s
- d) Pressure - 2 to 10 bar
- e) Flow rate - 5 to 30 microns

- **Abrasive Jet**

- a) Velocity - 100 to 300 m/s
- b) Mixing ratio – Volume flow rate of abrasives/Volume flow rate of gas
- c) Stand off distance – SOD - 0.5 to 15 mm.
- d) Impingement angle – 60 to 90 deg.

- **Nozzle**

- a) Material – WC/Sapphire
- b) Diameter – 0.2 to 0.8 mm
- c) Life – 300 hours for sapphire, 20 to 30 hours for WC

- **Process capability**

1. Material removal rate – 0.015 cm³/min
2. Narrow slots – 0.12 to 0.25 mm ± 0.12 mm
3. Surface finish -0.25 micron to 1.25 micron
4. Sharp radius up to 0.2 mm is possible

5. Steel up to 1.5 mm, Glass up to 6.3 mm is possible to cut
6. Machining of thin sectioned hard and brittle materials is possible.

1.10.2 Parameters in AJM

The parameters which affect MRR and accuracy of the machining process are :

1. Carrier gas :

- A carrier gas used in the process must not flare excessively when discharged from the nozzle into the atmosphere. A gas used should be non-toxic, cheap, easily available and capable of being dried easily.
- Commonly used gases are air, nitrogen and carbon di-oxide.
- If an air compressor is used proper line filters must be fixed to avoid water or oil contamination of the abrasive powders. Since these contamination presents clogging problem in the nozzle.
- Oxygen should never be used due to hazardous problem.

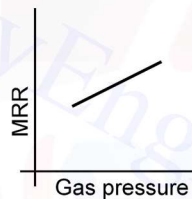

Fig. 1.6

2. Types of abrasives :

- The abrasive used in the process should have a sharp and irregular shape and should have excellent flow characteristic.
- Commonly used abrasives are aluminium oxide and silicon carbide for general machining and grooving whereas sodium bi-carbonate for fine finishing and dolomite for etching and light cleaning purpose.
- **Reuse of abrasives is not recommended** since the cutting ability of abrasive decrease after the usage and also the contamination of wear materials clogging the nozzle and the cutting unit orifices.
- It is important to note that sodium bicarbonate is hygroscopic and will absorb moisture if heated above 49° thus rendering it useless, if allowed to become moist.

3. Jet velocity :

- The kinetic velocity of the abrasive jet is utilised for metal removal by erosion.

- The velocity is a function of nozzle pressure, nozzle design and abrasive grain size.
- Higher nozzle pressure results in greater MRR. Also, higher grain size produces higher MRR. The inside diameter of the nozzle is about 0.04 mm.

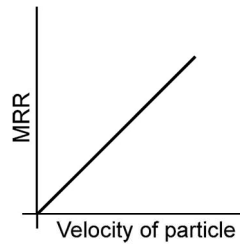

Fig. 1.7

4. Stand - Off Distance (SOD) or Nozzle Tip Distance (NTD) :

- It is the distance between the face of the nozzle and working surface of the workpiece to be machined.
- Generally, it is kept about 0.7 mm to 1.0 mm.
- The shape and size of cavity produced as well as the surface of the workpiece is affected by NTD.
- If NTD increases the velocity of abrasive particles striking on the workpiece also increases, hence MRR also increases.
- Initially MRR increases with NTD after which it remains unchanged for a certain NTD and then falls gradually. Fig. 1.8 shows effect of NTD on MRR

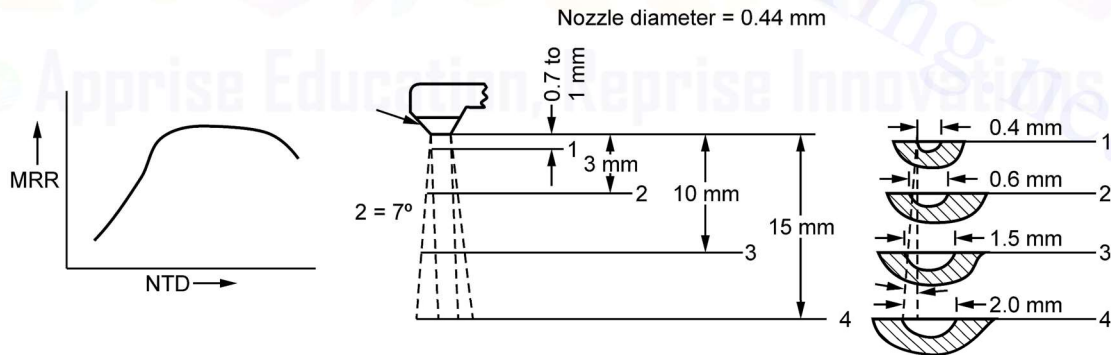

Fig. 1.8

5. Size of the abrasive grain

- The MRR in the AJM process depends on the size of the abrasive grain.
- The abrasives are available in many sizes ranging from 10μ to 50μ . But best cutting results have been obtained if the size of the bulk ranges from 15μ to 40μ

- **Finer grains** are less irregular in shape and possess lesser cutting ability. They are used for polishing, fine deburring and cleaning operations.
- **Too fine powder** may tend to cake in the abrasive storage tank and hence reduce the rate of flow and affects the MRR.
- **Over size particles** also affect the MRR by plugging the orifice and reduce the velocity of the jet by means of its weight.
- **Coarse grains** are normally recommended for cutting and peening operations.

6. Effect of mixing ratio on MRR

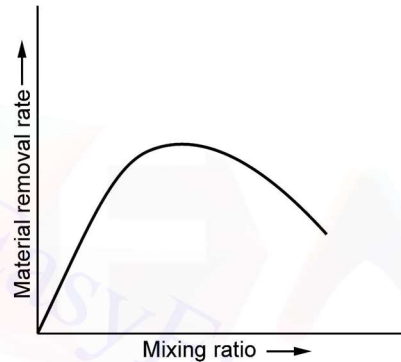

Fig. 1.9

- Increased mass flow rate of abrasive will result in a decreased velocity of fluid and will thereby decrease the available energy for erosion and ultimately the MRR.
- It is convenient to explain this fact by the term MIXING RATIO. Which is defined as

$$\text{Mixing ratio (M)} = \frac{\text{Volume flow rate of abrasives per unit time}}{\text{Volume flow rate of carrier gas per unit time}}$$

The effect of mixing ratio on the material removal rate is shown above.

- A large value of M results in higher rate of material removal up to a certain limit and then it gets reduced because a large abrasive flow rate decreases the jet velocity which is responsible for causing the impact of the abrasive on to the work piece material.
- Also it presents the problem of clogging the nozzle. Thus for a given condition there is an optimum mixing ratio that results in a maximum MRR. But when the abrasive mass flow rate increases the MRR also increases.

7. Work Piece Material

- The AJM process is best suited for machining hard, brittle and heat sensitive metals, alloys and non-metallic materials like Quartz, Germanium, Silicon, Glass, Ceramics, Mica and refractory materials of thin sections.

8. Shape of Cut

- It is not possible to machine or cut parts with sharp corners because of stray cutting.

9. Nozzle Design

- The nozzle has to withstand the corrosive action of abrasive particles and must be made of material which offers high resistance to wear.
- The nozzle is normally made of tungsten carbide or sapphire.
- The life of the nozzle is ascertain. A tungsten carbide nozzle lasts between 12 hours and 30 hours.
- A sapphire nozzle lasts around 300 hrs. Operation when used with in 27 m abrasive powder.
- Nozzles are made with an external taper to minimize the secondary effects.

10. Accuracy and surface finish

- The control of the various parameters results in a tolerance in the region of ± 0.05 mm
- Normal production using AJM technique ends up in an accuracy of ± 0.1 mm
- The corner radius obtained can be limited to 0.1 mm.
- Taper is around 0.05 mm per 10 mm penetration.
- Slots as narrow as 0.12 to 0.25 mm can be produced.
- The surface finish ranges from 0.4 to 1.2 mm in most of the applications.

Advantages of AJM

- Brittle materials of thin sections can be easily machined.
- No direct contact between the tool and workpiece, hence less damage to the workpiece surface.
- Holes of any shape and intricate cavities can be machined.
- Initial investment is low as compared to other methods.
- Power consumption is low.

Disadvantages of AJM

- AJM is suitable only for brittle materials, as MRR is high for brittle materials.
- Machining accuracy obtained is poor i.e. upto ± 50 microns.
- MRR is low i.e. upto $0.05 \text{ cm}^3/\text{hr}$.

- There is always a chance of abrasive particles getting inserted in the work material, hence cleaning needs to be done after machining.
- The used abrasive powder can not be reused.
- Process tends to pollute the environment.

Applications of AJM

- The process is best suited for machining brittle and heat sensitive materials like glass, quartz, sapphire, ceramics, etc.
- It is used for drilling holes, cutting slots, cleaning hard surfaces, deburring, polishing, etc.
- It is used for producing high quality surface.
- It is used for reproducing designs on a glass surface with the help of masks made of rubber, copper, etc.
- Used for etching markings on glass cylinders.
- Used for frosting interior surfaces of glass tubes.
- Used for cutting thin sectioned fragile components made of glass, refractories, ceramics, mica, etc.
- Used for aperture drilling for electronic microscopes

1.10.3 Metal Removal Rate (MRR) in AJM

- The material removal rate in abrasive set machining is given by,

$$\text{M.R.R.} = K \cdot N \cdot d^3 \cdot v \left(\frac{3}{2}\right) \cdot \left(\frac{\rho}{12H}\right) \left(\frac{3}{2}\right) \quad \dots (1.1)$$

where,

K = Constant

N = Number of abrasive particles impacting per unit time.

d = Mean diameter of abrasive particles.

v = Abrasive particles velocity

ρ = Density of abrasive particle

H = Hardness of work material

1.11 Abrasive Water Jet Machining (AWJM)

History

- Dr. Franz in 1950's first studied UHP (Ultra High –Pressure) water cutting for forestry and wood cutting (pure WJ) 1979 Dr. Mohamed Hashish added abrasive particles to

increase cutting force and ability to cut hard materials including steel, glass and concrete (abrasive WJ)

- First commercial use was in automotive industry to cut glass in 1983
- Soon after, adopted by aerospace industry for cutting high-strength materials like Inconel, stainless steel and titanium as well as composites like carbon fiber.
- We know that, Abrasive Jet Machining (AJM), Abrasive Flow Finishing (AFF) and Ultrasonic Machining (USM) are the processes which make use of abrasives for machining of materials.
- In case of AJM, air driven abrasive jet strikes the workpiece and removes the material whereas in USM abrasive grains in liquid slurry strike the liquid surface and cut the material at low MRR.
- Now - a - days a hybrid process called abrasive Water Jet Machining or Cutting (AWJM or AWJC) is used which makes use of abrasives with water jet for machining.
- This process is similar to AJM except that, in this case water is used as a carrier fluid instead of gas.
- This process is mainly suitable for electrically non -conductive and difficult to machine materials more rapidly and efficiently than the other processes.

Definition

- Abrasive water jet machining is a mechanical energy based material removal process in which abrasives are mixed with water to form the abrasive slurry.
- It is a material removal process where the material is removed or machined by the impact erosion of the high velocity stream of water and abrasive mixture which is focused on to the work piece.
- This process is similar to abrasive jet machining except that the water is used as a carrier medium instead of dry air.

Working Principle

- During the process, a jet of water and a stream of abrasives coming from two different directions, mix up and flows through the abrasive jet nozzle. Refer Fig. 1.10.
- Because of nozzle, velocity of the abrasive rises rapidly.
- Thus, a high velocity stream of mixture of abrasives and water impinges on the surface of workpiece and removes material.
- According to the material of workpiece, the removal of material may occur due to erosion, shear or due to rapidly change in localized stress fields.

- This process is used for cutting, drilling and cleaning of hard materials. It is capable to cut ceramics, composites, rocks, metals, etc.
- The pressure at which water jet operates is about 400 MPa and jet velocity is about 900 m/s.
- The commonly used abrasives in this process are silica, garnet and silicon carbide. For hard materials, hard type of abrasive is used.

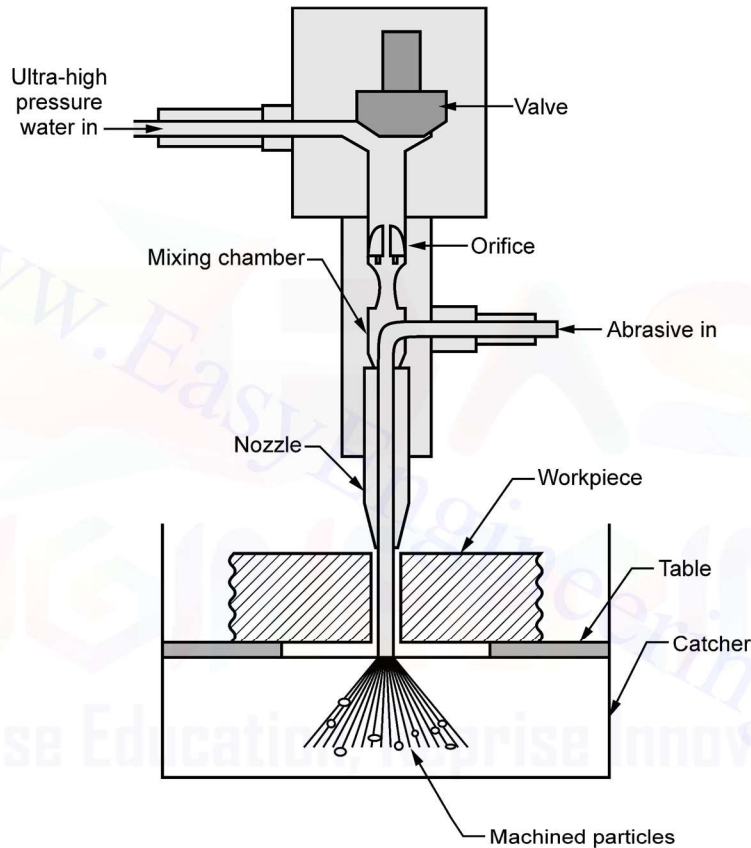

Fig. 1.10 : Working principle of AWJM

- The set-up of AWJM consists of four important elements as follows :

- | | |
|--------------------------------|--------------------------|
| i) Pumping System | ii) Abrasive Feed System |
| iii) Abrasive Water Jet Nozzle | iv) Catcher |

i) Pumping system

- It produces high velocity water jet by pressurizing water with the help of intensifier.
- For this purpose a high pressure motor is also required.

ii) Abrasive feed system

- This system delivers a controlled flow of abrasive particles to the jet nozzle. It delivers a stream of dry abrasives to the nozzle.
- The flow of water jet in a mixing chamber or tube is responsible to create enough suction for the flow of the abrasives.
- The rate of flow of abrasives can be adjusted by changing the size of the control orifice.

iii) Abrasive water jet nozzle

- This nozzle performs mixing of abrasive jet and water, and forms a high velocity water abrasive jet.
- It gives a coherent and focused abrasive stream at exit of nozzle. This nozzle is made of hard materials like sapphire, tungsten carbide or boron carbide.
- The abrasive water jet nozzle may be single jet side feed type or multiple jet central feed type. Refer Fig. 1.11.

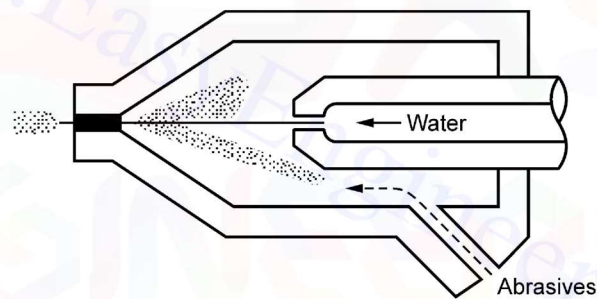

(a) Single jet single feed nozzle

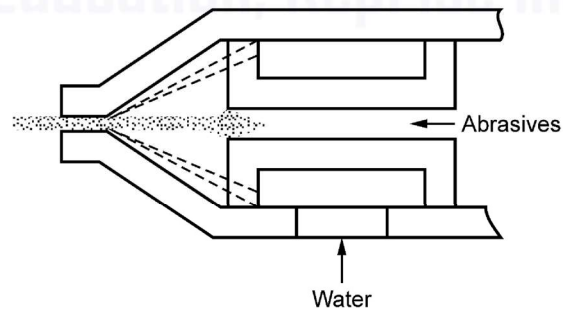

(b) Multiple jet central feed nozzle

Fig. 1.11 Abrasive water jet nozzle

- In a single jet side feed nozzle, the abrasives fed from the side and mix with water jet in the mixing chamber. These nozzles are less costly, simple but less efficient.
- In a multiple jet central feed nozzle, a centrally located abrasive feed system is surrounded by multiple water jets. It gives higher nozzle life and better mixing of abrasives and water jet.

iv) Catcher

- Catcher is a long narrow tube placed under the point of cut to capture the used jet.
- It is used when the nozzle is stationary and the workpiece moves.
- When the workpiece is stationary and the nozzle moves, water filled settling tank is provided below the workpiece.
- “Catcher” is used to absorb the residual energy of the AWJ and dissipate the same.
- Figure shows three different types of catcher – water basin type, submerged steel balls and TiB₂ plate type.

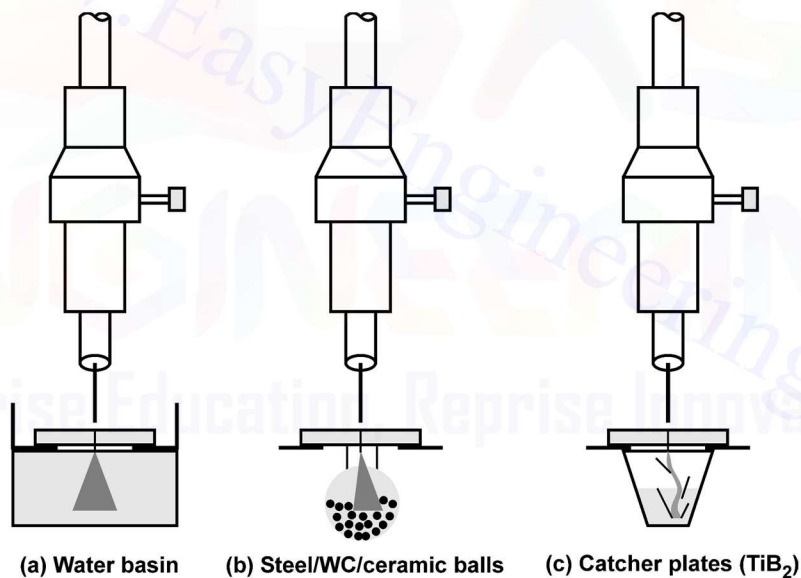

Fig. 1.12

1.11.1 Types of AWM

AWJ are mainly of two types,

i) Entrained type

ii) Suspended type

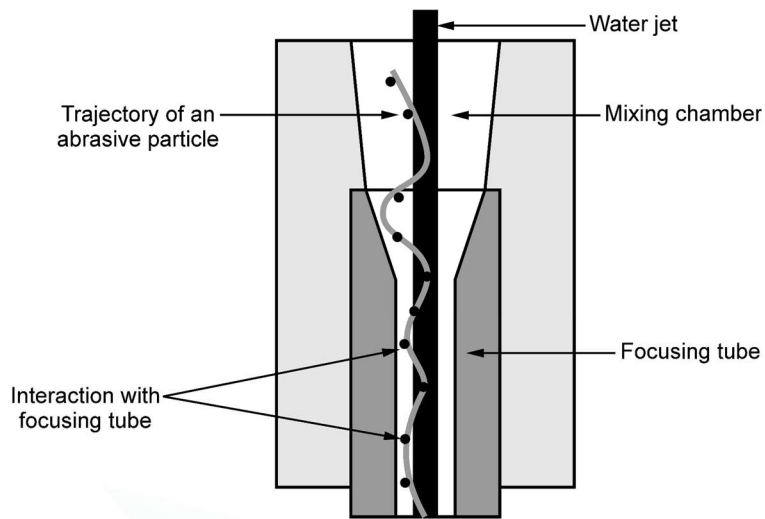

Fig. 1.13

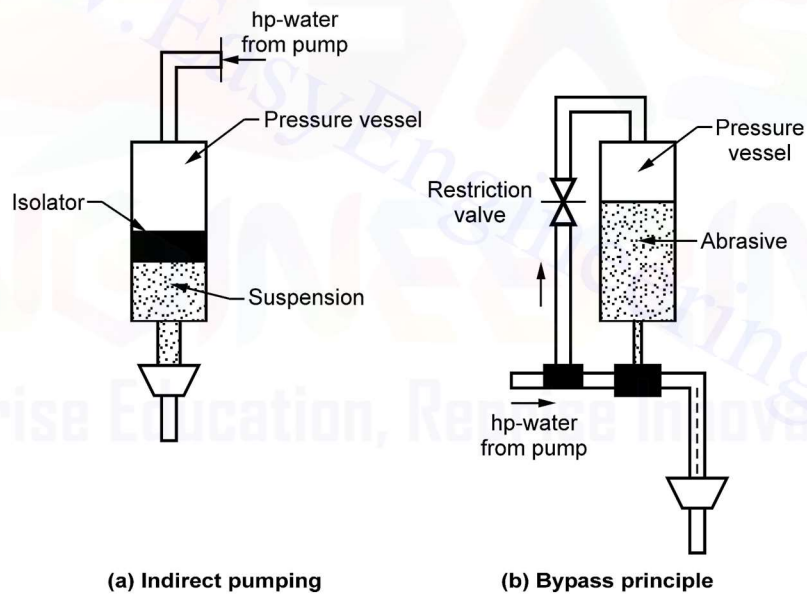

Fig. 1.14

- In entrained type AWJM, the abrasive particles are allowed to entrain in water jet to form abrasive water jet with significant velocity of 800 m/s. Such high velocity abrasive jet can machine almost any material.
- In suspension AWJM the abrasive water jet is formed quite differently. There are three different types of suspension AWJ formed by direct, indirect and Bypass pumping method.

1.11.2 Process Variables

The process variables in AWJM are as follows :

- Flow rate and pressure of water
- Type, size and flow rate of abrasives
- Water nozzle and abrasive jet nozzle design
- Feed rate and stand - off distance
- Material of workpiece
- Number of passes
- Mixing tube dimensions (length, diameter and cutting angle)

1) Pressure of the water

- P_c is the minimum critical pressure required to cut the material.
- A minimum critical pressure P_c exists because of the minimum abrasive particle velocity required to cut specific materials.
- The value of P_c for mild steel is between 20.7 and 27.5 MPa.

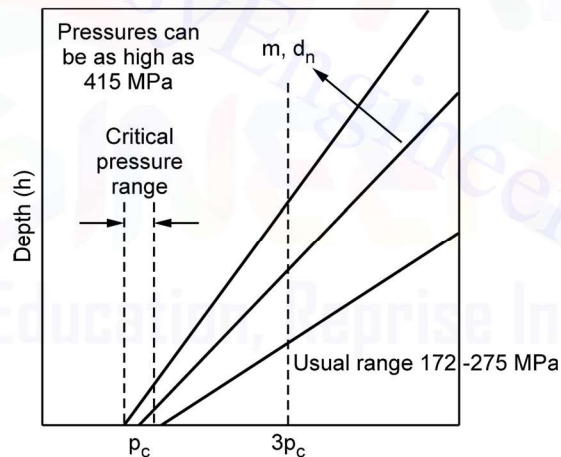

Fig. 1.15

2) Water flow rate

- Fig. 1.15 shows the depth of cut is affected by varying the water flow rate (increasing the nozzle diameter) while maintaining the constant pressure.
- As the flow rate increases, the slope of the curve decreases because the saturation point is reached.
- As the nozzle diameter increases and the water flow rate increases, the rate of increase in the particle velocity is reduced, thus reducing the depth of cut.

3) Abrasive flow rate

- Abrasive flow rate versus depth of cut is a linear relationship up to a point
- Above a critical flow rate, the cutting efficiency decreases.
- This is because of the fact that, as the abrasive flow rate increases (with a fixed water flow rate), particle velocity begins to decrease faster than the rate at which the number of abrasive particle impacts increase.

4) Abrasive particle size

- The most common abrasive particle sizes used for AWJM range from 100 to 150 grit
- An optimum abrasive particle size also exists for each particular nozzle mixing chamber configuration.

5) Abrasive type

- The type of abrasive used is also an important parameter.
- Garnet, silica and silicon carbide are the most commonly used abrasives.
- Selection of abrasive type is usually determined by the hardness of the material that is being cut.

6) Traverse rate

- When traverse rates are increased the depth of cut decreases.
- There is also a minimum critical traverse rate below which further increases in depth of cut are not obtained.
- If the traverse rate is not maintained at a relatively uniform velocity, a rough edge will result because of the nature of the process.

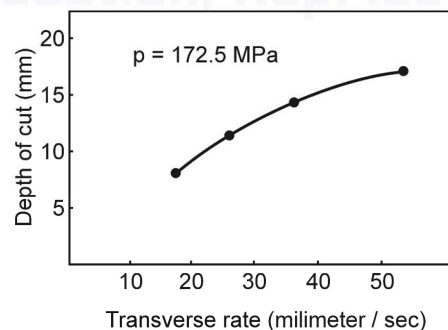

Fig. 1.16 Depth of cut Vs traverse rate

7) Stand-off-distance

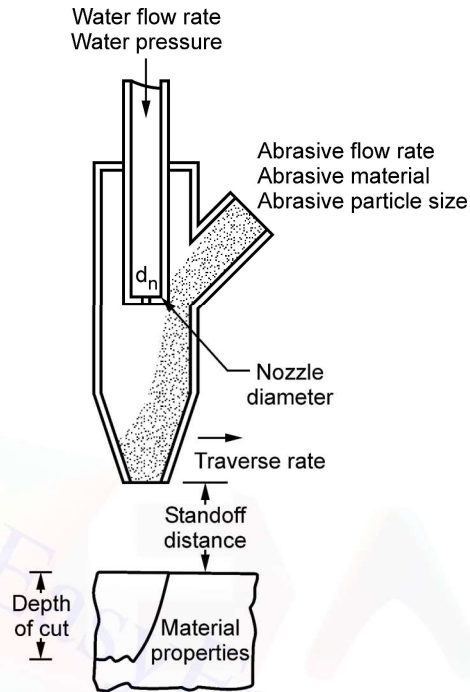

Fig. 1.17 Stand off distance

- Data generated by some researchers indicate that depth of cut is approximately linear relative to SOD. Increasing SOD decreasing the depth of cut.
- When mixing is efficient and process parameters are correct, a deviation in SOD of up to ± 12.7 mm can be tolerated without degradation of the cut quality.
- If SODs are increased to a distances of about 80mm, the process will no longer cut but will efficiently clean and de-scale surfaces.

1.11.3 Process Capabilities

- AWJM can be thought of as a combination of WJM and AJM principles.
- But in terms of capability, AWJM combines the best of both processes, resulting in a new process that can cut materials whether they are hard or soft at high rates and in very thick sections.
- AWJM can cut materials as thick as 200mm and still maintain a comparatively narrow kerf.
- Kerf width is a function of the material thickness and usually is between 1.5 and 2.3 mm.
- The resulting taper on the cut edge is a function of the material hardness,

- Where hard materials have the widest kerf at the top of the cut and soft materials have the widest kerf at the bottom of the cut.

Advantages

- It can cut electrically non - conductive and hard materials rapidly and efficiently.
- Cutting speed is high.
- The process has multi-direction cutting capacity.
- No fire hazards and no dust problem.
- High quality of machined surface is obtained.
- Recycling of abrasive particles is possible.
- The process requires low power.
- During the process, no thermal or distortion stresses.
- Make all sorts of shapes with only one tool.
- No heat generated.
- Unlike machining or grinding, waterjet cutting does not produce any dust or particles that are harmful if inhaled.
- The kerf width in waterjet cutting is very small, and very little material is wasted.
- Waterjet cutting can be easily used to produce prototype parts very efficiently. An operator can program the dimensions of the part into the control station, and the waterjet will cut the part out exactly as programmed. This is much faster and cheaper than drawing detailed prints of a part and then having a machinist cut the part out.
- Waterjets are much lighter than equivalent laser cutters, and when mounted on an automated robot. This reduces the problems of accelerating and decelerating the robot head, as well as taking less energy.

Disadvantages

- This process can cut limited number of materials economically. During the cutting of tool steel and other hard materials, the cutting rate is low hence it requires more time. This increases the cost of machining.
- Very thick parts with good dimensional accuracy cannot be cut by this process.
- Taper is also a problem with waterjet cutting in very thick materials. Taper is when the jet exits the part at a different angle than it enters the part, and can cause dimensional inaccuracy. Decreasing the speed of the head may reduce this, although it can still be a problem.

Applications

- This process is suitable for cutting of metals (copper, lead, tungsten, copper alloys, aluminium, tungsten carbide, etc.) and non - metals (graphite, silica, glass, concrete, acrylic, etc.).
- It is used to machine the sandwiched honeycomb structural material used in the aerospace industries.
- It is used for cutting materials in a number of industries like aerospace, oil, foundry, automotive, construction and glass.
- Different types of steels can be cut into different shapes like plate, tube, corrugated structure, etc.

1.12 Water Jet Machining (WJM)

Definition :

In this process high pressure and high velocity stream of water is used to cut the relatively softs and non-metallic materials like paper boards, wood, plastics, rubber, fibre glass, leather etc.,

Introduction

- Key element in WJM is a jet of water.
- Water jet travels at velocities as high as 900 m/s.
- When the water stream strikes a work piece surface, the erosive force of water removes the material rapidly.
- The water, in this case, acts like a saw and cuts a narrow groove in the work piece material.
- True cold cutting process – no HAZ (Heat Affected Zones), mechanical stresses or operator and environmental hazards

Principle

- The water jet machining involves directing a high pressure (150-1000 MPa) high velocity (540-1400 m/s) water jet (faster than the speed of sound) to the surface to be machined.
- The fluid flow rate is typically from 0.5 to 2.5 ltr/min
- The kinetic energy of water jet after striking the work surface is reduced to zero.
- The bulk of kinetic energy of jet is converted into pressure energy.

- If the local pressure caused by the water jet exceeds the strength of the surface being machined, the material from the surface gets eroded and a cavity is thus formed.
- Water is the most common fluid used, but additives such as alcohols, oil products and glycerol are added when they can be dissolved in water to improve the fluid characteristics.

Equipment

Typical work materials involve soft metals, paper, cloth, wood, leather, rubber, plastics, and frozen food. If the work material is brittle it will fracture, if it is ductile, it will cut well.

Water jet machining consists of :

- | | | |
|-------------------------|-----------------------|----------------|
| 1. Hydraulic pump | 2. Intensifier | 3. Accumulator |
| 4. High pressure tubing | 5. Jet Cutting nozzle | 6. Catcher |

1. Hydraulic pump

- Powered from a 30 kilowatt (kW) electric motor
- Supplies oil at pressures as high as 117 bars.
- Compressed oil drives a reciprocating plunger pump termed an *intensifier*.
- The hydraulic pump offers complete flexibility for water jet cutting and cleaning applications.
- It also supports single or multiple cutting stations for increased machining productivity.

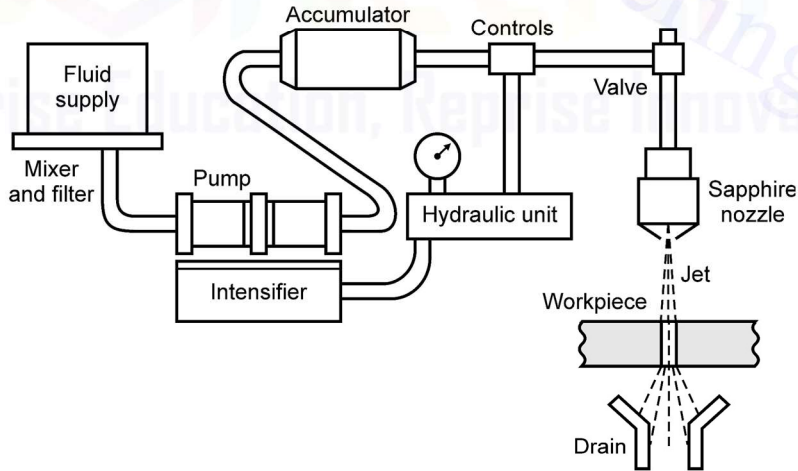

Fig. 1.18

2. Intensifier

- Accepts the water at low pressure (typically 4 bar) and expels it, through an accumulator, at higher pressures of 3800 bar.
- The intensifier converts the energy from the low-pressure hydraulic fluid into ultra high pressure water.
- The hydraulic system provides fluid power to a reciprocating piston in the intensifier center section.
- A limit switch, located at each end of the piston travel, signals the electronic controls to shift the directional control valve and reverses the piston direction.
- The intensifier assembly, with a plunger on each side of the piston, generates pressure in both directions.
- As one side of the intensifier is in the inlet stroke, the opposite side is generating ultra high pressure output.
- During the plunger inlet stroke, filtered water enters the high-pressure cylinder through the check valve assembly.
- After the plunger reverses direction, the water is compressed and exits at ultrahigh pressure.

3. Accumulator

- Maintains the continuous flow of the high-pressure water and eliminates pressure fluctuations.
- It relies on the compressibility of water (12 percent at 3800 bar) in order to maintain a uniform discharge pressure and water jet velocity, when the intensifier piston changes its direction.

4. High pressure tubing

- Transports pressurized water to the cutting head.
- Typical tube diameters are 6 to 14 mm.
- The equipment allows for flexible movement of the cutting head.
- The cutting action is controlled either manually or through a remote-control valve specially designed for this purpose.

5. Jet cutting nozzle

- Nozzle provides a coherent water jet stream for optimum cutting of low-density, soft material that is considered unmachinable by conventional methods.
- Nozzles are normally made from synthetic sapphire.
- About 200 h of operation are expected from a nozzle, which becomes damaged by particles of dirt and the accumulation of mineral deposits on the orifice due to erosive water hardness.
- A longer nozzle life can be obtained through multistage filtration, which removes undesired solids of size greater than 0.45 μm .
- The compact design of the water jet cutting head promotes integration with motion control systems ranging from two-axis (*XY*) tables to sophisticated multi-axis robotic installations.

Recommended Nozzle Material	Operating Conditions
Carbide	Dirty, unfiltered water, Pressure below 140 MPa
Steel	Water filtered to 25 micron or better, pressure below 140 MPa
Sapphire	Water filtered to micron or better, Pressures above 140 MPa
Diamond nozzle shows better performance over sapphire nozzle at high pressure in terms of jet stability.	

6. Catcher

- Acts as a reservoir for collecting the machining debris entrained in the water jet.
- Moreover, it reduces the noise levels [105 decibels (dB)] associated with the reduction in the velocity of the water jet from Mach 3 to subsonic levels.

1.12.1 Process Parameters Affecting WJM

JET Nozzle

- Standoff distance - Gap between the jet nozzle (0.1 - 0.3 mm diameter) and the workpiece (2.5 - 6 mm).
- However for materials used in printed circuit boards, it may be increased to 13 to 19 mm.
- But larger the standoff distance, smaller would be the depth of cut.

- When cutting fiber-reinforced plastics, reports showed that the increase in machining rate and use of the small nozzle diameter increased the width of the damaged layer.

JET Fluid

- Typical pressures used are 150 to 1000 MPa to provide 8 to 80 kW of power.
- For a given nozzle diameter, increase in pressure allows more power to be used in the machining process, which in turn increases the depth of the cut.
- Jet velocities range between 540 to 1400 m/s.
- The quality of cutting improves at higher pressures by widening the diameter of the jet and by lowering the traverse speed.
- Under such conditions, materials of greater thicknesses and densities can be cut.
- Moreover, the larger the pump pressure, the greater will be the depth of the cut.
- The fluid used must possess low viscosity to minimize the energy losses and be noncorrosive, nontoxic, common, and inexpensive.
- Water is commonly used for cutting alloy steels.

Workpiece

- Brittle materials will fracture, while ductile ones will cut well.
- Material thicknesses range from 0.8 to 25 mm or more.
- Table above shows the cutting rates for different material thicknesses.

Material	Thickness, mm	Feed rate, m/mim
Leather	2.2	20
Vinyl chloride	3.0	0.5
Polyester	2.0	150
Kevlar	3.0	3
Graphite	2.3	5
Gypsum board	10	6
Corrugated board	7	200
Pulp sheet	2	120
Plywood	6	1

Applications

- WJM is used on metals, paper, cloth, leather, rubber, plastics, food, and ceramics.
- It is a versatile and cost-effective cutting process that can be used as an alternative to traditional machining methods.
- It completely eliminates heat-affected zones, toxic fumes, recast layers, work hardening and thermal stresses.
- It is the most flexible and effective cleaning solution available for a variety of industrial needs.
- In general the cut surface has a sandblast appearance.
- Moreover, harder materials exhibit a better edge finish.
- Typical surface finishes ranges from 1.6 μm Root Mean Square (RMS) to very coarse depending on the application.
- Tolerances are in the range of $\pm 25 \mu\text{m}$ on thin material.
- Both the produced surface roughness and tolerance depend on the machining speed.

1. Cutting

- WJM is limited to fiberglass and corrugated wood.
- Fig. 1.19 shows typical example of water jet cutting of marble and application in the food industry.



Fig. 1.19 Applications of WJM in marble cutting and food industries

2. Drilling

- The process drills precision-angled and -shaped holes in a variety of materials for which other processes such as EDM or EBM are too expensive or too slow.

3. Machining of fiber-reinforced plastics

- In this case the thermal material damage is negligible.
- The tool, being effectively pointed, accurately cuts any contours.
- The main drawback is the deflection of the water jet by the fiber embedded in the matrix, which protrudes after machining.

- The feed rate attainable depends on the surface quality required.
- Table below gives the limiting feed rates for water jet cutting of fiber-reinforced plastics.

Material	Thickness, mm	Feed rate, m/min
Glass fiber-reinforced polymers (GFRP) (laminate)	2.2	1.8 – 6.0
	3.0	1.4 – 5.0
	5.0	0.7 – 6.0
Aramid fiber-reinforced polymers (AFRP) (weave)	1.0	10.0
	2.0	2.4 – 4.0

4. Cutting of rocks

- Water jet cutting of a 51 mm deep slot in granite using two oscillating jets at 275 MPa during 14 passes at a 25.4 mm/s feed rate has been reported by McGeough (1988).
- Moreover an oscillating nozzle system operating at the same feed rate and pressure of 172 MPa, with the standoff distance adjusted every pass was used to cut a 178 mm deep slot in sandstone.

5. Deburring

- The method uses large pressures to remove large burrs (3 mm height) in 12 mm diameter drilled holes in a hollow molybdenum-chromium steel shaft at 15 s using 700 bar pressure and a flow rate of 27 L/min.
- In this method burrs are broken off by the impact of water.
- A higher pressure (4000 bar) and a lower flow rate (2.5 L/min) are used to remove burrs from nonmetallic materials.

6. Cutting of PCBs

- Using a small-diameter water jet, a printed circuit board (PCB) can be cut at a speed that exceeds 8 m/min, to the accuracy of ± 0.13 mm.
- Boards of various shapes for use in portable radios and cassette players can be cut using Computer Numerical Control (CNC) technology.

7. Surface treatment

- Removing deposits and residues without toxic chemicals, which eliminates costly clean up and disposal problems.

- Surface cleaning of pipes and castings, decorative finishing, nuclear decontamination, food utensil cleaning, degreasing, polishing, preparation for precise inspection, and surface texturing.
- Economical surface preparation and coating removal.
- Removing corrosion, spray residue, soluble salts, chemicals, and surface damage prior to recoating or painting.

8. Wire stripping

- Can remove the wire insulating material without damaging the metal or removing the tinning on the copper wire.
- Processing time can be decreased to about 20 % of the manual stripping method.

Advantages

- It has multidirectional cutting capacity.
- No heat is produced.
- Cuts can be started at any location without the need for predrilled holes.
- Wetting of the workpiece material is minimal.
- There is no deflection to the rest of the workpiece.
- The burr produced is minimal.
- The tool does not wear and, therefore, does not need sharpening.
- The process is environmentally safe.
- Hazardous airborne dust contamination and waste disposal problems that are common when using other cleaning methods are eliminated.
- There is multiple head processing.
- Simple fixturing eliminates costly and complicated tooling, which reduces turnaround time and lowers the cost.
- Grinding and polishing are eliminated, reducing secondary operation costs.
- The narrow kerf allows tight nesting when multiple parts are cut from a single blank.
- It is ideal for roughing out material for near net shape.
- It is ideal for laser reflective materials such as copper and aluminum.
- It allows for more accurate cutting of soft material.
- It cuts through very thick material such as 383 mm in titanium and 307 mm in Inconel.

Limitations

- Very thick parts can not be cut with water jet cutting and still hold dimensional accuracy. If the part is too thick, the jet may dissipate some, and cause it to cut on a diagonal, or to have a wider cut at the bottom of the part than the top. It can also cause a rough wave pattern on the cut surface.
- It is not suitable for mass production because of high maintenance requirements.

Water Jet Lag

Recent developments in WJM

- High pressure water jet
- Nozzle shape

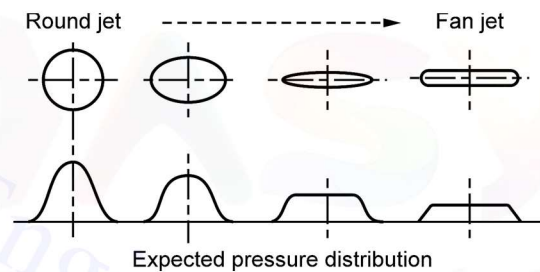
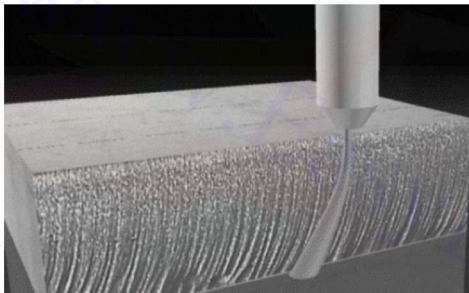

Fig. 1.20

- Water jet forming
- Water jet in mining
- Water jet in food processing plant
- Medical applications
- Water jet peening
- Water jet in packaging industry
- Water jet guided laser technology

1.13 Ultra-Sonic Machining

- The term ultrasonic is used to describe a vibratory wave of a frequency above that of the upper limit of the human ear.
- There are two types of waves namely shear wave and longitudinal wave.
- Longitudinal waves are mostly used in the ultrasonic applications, since they are easily generated.

Construction

- Fig. 1.21 shows the whole setup of Ultra Sonic Machining method. It consists of an electromechanical transducer for producing frequency upto 20 kHz to 30 kHz, which is more than the upper limit of audible frequency of the human ear, and makes the process silent.
- It also uses slurry of small abrasive particles which is forced against the workpiece by using a vibrating tool and it removes the material of workpiece in the form of small chips.
- The tool which is applied to the workpiece is generally made of soft materials and slurry is fed either manually or through pump. Sometimes hollow tools are also used because the slurry can feed through it easily.
- The transducer used in the process is made up of a magneto structive material, which is excited by the high frequency electric current and generates mechanical vibrations

Working

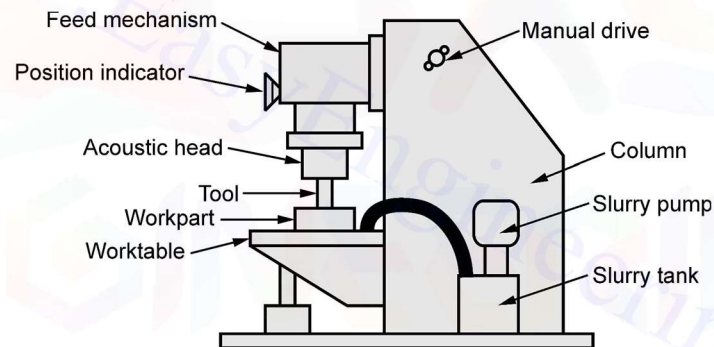

Fig. 1.21 Principal components of an ultrasonic machine

- A high frequency electric current is supplied by the ultrasonic oscillator to the ultrasonic transducer, which converts electrical energy into mechanical vibrations.
- To get the amplitude from 0.01 mm to 0.1 mm, vibrations of 20 kHz to 30 kHz are generated.
- These vibrations are transmitted to the cutting tool through the transducer cone, connecting body and tool holder.
- Due to these vibrations, tool vibrates in a longitudinal direction as shown in Fig. 1.21.
- The shape of the cutting tool is mirror image as that of which is produced on the workpiece.
- USM is also called as **Ultrasonic Grinding** or **Impact Grinding**.

Equipment :

Ultrasonic machining consists of :

- | | |
|----------------------------|------------------------|
| 1. Ultrasonic transducer | 2. Concentrator |
| 3. Tool | 4. Abrasive slurry |
| 5. Abrasive feed mechanism | 6. Tool feed mechanism |

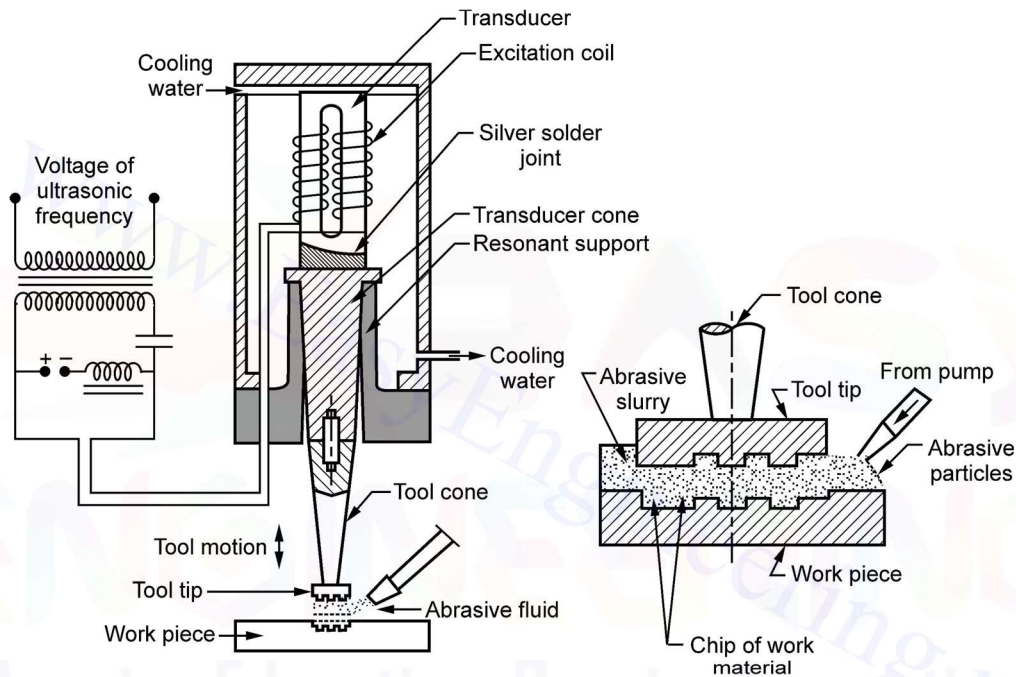

Fig. 1.22 Schematic representation of ultrasonic machining process

1. Ultrasonic transducer

The equipment consists an ultrasonic transducer for which the electrical input is given, to obtain the required mechanical vibration. The device used for converting any type of energy into ultrasonic waves or vibrations is called **ultrasonic transducer**. The electrical energy is converted into mechanical vibrations for carrying out the machining operation. The high frequency electrical signal is transmitted to traducer which converts it into high frequency low amplitude vibration. Essentially transducer converts electrical energy to mechanical vibration.

There are two types of transducer used

- | | |
|------------------------------|-----------------------------------|
| i) Piezo electric transducer | ii) Magneto-stricitve transducer. |
|------------------------------|-----------------------------------|

i) Piezo electric transducer

- Piezo electric transducer have the capability of converting electrical energy into mechanical vibrations.
- These transducer generate a small electric current when they are compressed. Also when the electric current is passed though crystal it expands.
- When the current is removed, crystal attains its original size and shape. Such transducers are available up to 900 Watts. Piezo electric crystals have high conversion efficiency of 95 %.
 - More efficient
 - Less loss of power
 - Do not require cooling

ii) Magneto-strictive transducer :

- These also changes its length when subjected to strong magnetic field. (Magnetostrictive effect is the one in which the material changes its dimensions in response to a magnetic field).
- These transducer are made of nickel, nickel alloy sheets. Their conversion efficiency is about 20-30 %. Such transducers are available up to 2000 Watts.
- The maximum change in length can be achieved is about 25 microns.

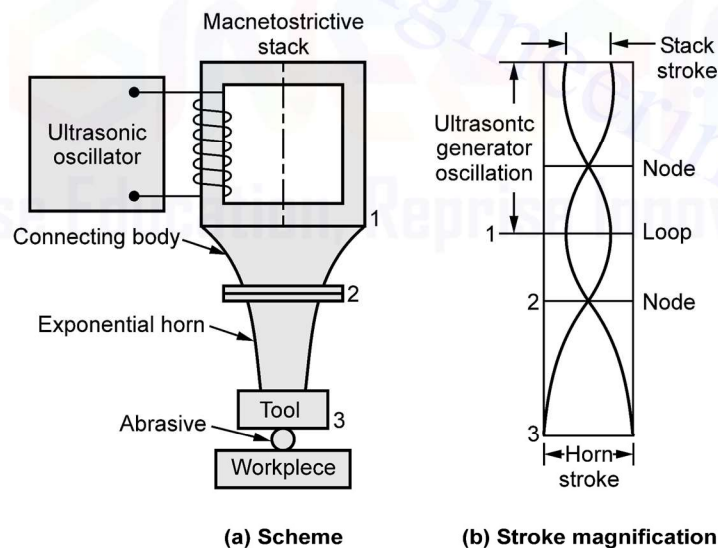

Fig. 1.23

- The magnetostrictive transducer consists of an excitation coil wound around a laminated nickel core.

- The magnetostrictive materials employed are nickel, Iron-cobalt called Permendur, Iron-Aluminium as Alfer.
- Nickel is widely used because of its high strength and good insulating property. The nickel core present in the transducer unit contracts and expands in response to the influence of a rapidly alternating current.
- Under the action of the electromagnetic field, set up by the input electrical power supply, the magnetostrictive stack is periodically magnetized and its length changes. The periodical shortening and lengthening of the stack is synchronous with the generator frequency and initiates the vibration.
- The amplitude of vibration is of the order between 0.1 mm to 0.06 mm. Eddy current losses of the transformer can be reduced by using Ferro-magnetic material in the form of insulated laminations assembled into a pack.
- A fair amount of the given input energy to the transducer appears as a heat so cooling is necessary. If the machine is up to 50 W capacity, air cooling is sufficient. But for higher capacity 50 W water cooling must.
- Magnetostrictive transducer,
 - Generally found in old machines
 - Less efficient due to high eddy current losses
 - Requires cooling.
- The transducer may be of Piezo-electric or Magnetostrictive type depending upon the choice of the choice of operation to be performed on a specific work piece materials.
- The amplitude of vibration obtained from the transducer is inadequate for doing any operation and hence the tool is connected to the transducer by means of a concentrator to produce the desired amplitude at the tool end.

Notes : The electrical input circuit of an ultrasonic transducer consists of an **ultrasonic oscillator and power amplifier** (Also called generator) which converts low frequency Electrical energy (50 Hz) to High Frequency electrical energy (25 kHz).

2. Concentrator or tool holder or horn

- Concentrator provides the link between the tool and transducer. It is also called as **tool cone, horn, and wave guide or tool holder**. The tool holder holds and connects the tool to the transducer. It virtually transmits the energy and in some cases, increases the amplitude of vibration.

- The different types of concentrators used are,
 1. Exponential type
 2. Conical type
 3. Stepped type

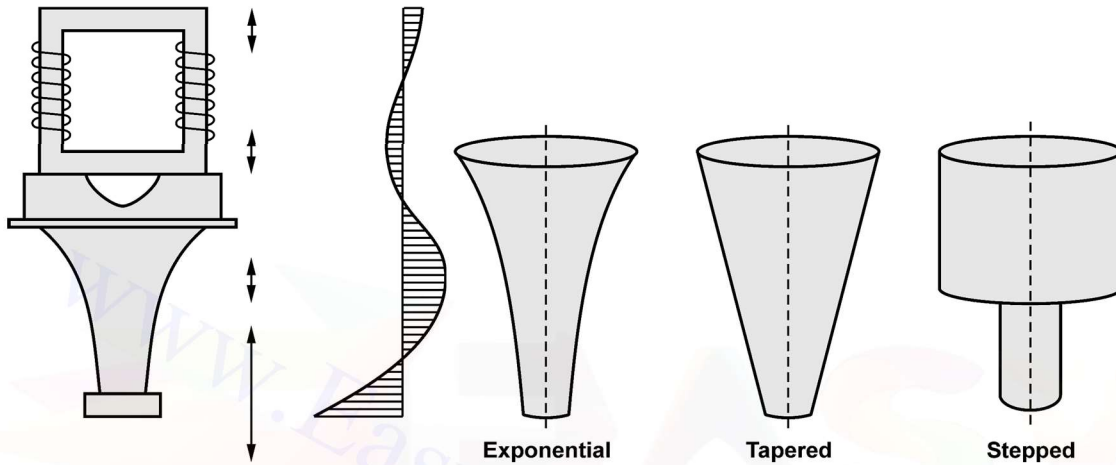

Fig. 1.24

Concentrator materials

- The horn or concentrator are generally made of monelmetal or stainless steel or titanium alloy or aluminium which can be fitted to the transducer either by brazing or to a connecting body made of Monel metal at a fixed nodal point.
- **Monel metal** (Monel is a group of **nickel alloys**, primarily composed of nickel (up to 67 %) and **copper**, with small amounts of iron, manganese, carbon, and silicon.) **is the best one** to be used as a tool holder which has properties of same as titanium and it can also be brazed easily.
- **Stainless steel is not preferred** because of its low fatigue strength. It is used only for low amplitude applications.

The tool holders or concentrators are available as

- | | |
|------------------------|---------------------|
| i) Non-amplifying type | ii) Amplifying type |
|------------------------|---------------------|

- i) Non-amplifying types produce the same amplitude of vibration at end where the tool is connected to the given input amplitude. They are normally of cylindrical cross section.

- ii) Amplifying tool holders are capable of amplifying at end where the tool is connected and remove materials 10times faster than the non-amplifying type.

Disadvantages of amplifying concentrator :

- Higher fabrication cost.
- Poor surface finish.
- Need for frequent tuning to maintain resonance.
- Tool holders are more expensive, demand higher operating cost.

3. Tool

- Tool is normally fixed at the end of the concentrator.
- It is fixed either by brazing, soldering or fastened to the concentrator.
- It must be ductile and tough rather than hard.
- As the ratio of the work piece hardness and tool hardness increases the MRR decreases.
- In practice slenderness ratio of the tool should not exceed 20.
- A smaller contact area enhances better abrasive flow and so high penetration is obtained.
- Also if the cutting path is long, due to poor scavenging from the innermost areas, the cutting is inefficient.
- The tool shape is normally the mirror image of the cavity to be produced along with the tolerance for abrasive particle size and tool wear considerations.
- **Sonotrode** : In ultrasonic machining, welding and mixing, a **sonotrode** is a tool that creates ultrasonic vibrations and applies this vibrational energy to a gas, liquid, solid or tissue. Sonotrodes of small diameter are sometimes called probes.

Note : The tool tip or tool face can be made from diamond, tool steel, Stainless steel, cold rolled steel, brass or copper.

4. Abrasive slurry

- The abrasive slurry is nothing but a mixture of abrasive grains and the carrier fluid generally water. The abrasive slurry is circulated by a pump between the tool and work piece interface.
- Some of the abrasive used are,
 1. Aluminium Oxide (Al_2O_3 Alumina)
 2. Boron carbide (B_4C)
 3. Silicon carbide (SiC)
 4. Diamond dust
 5. Boron silicarbide

Boron carbide	<ul style="list-style-type: none"> ➤ Best and most efficient and fastest cutting abrasive. ➤ Expensive ➤ Used for cutting harder materials like tungsten carbide, tool steel and precious stones.
Silicon carbide	<ul style="list-style-type: none"> ➤ Used for glass, germanium and some ceramics ➤ Used for maximum application
Alumina	<ul style="list-style-type: none"> ➤ Less efficient than boron carbide
Aluminium oxide	<ul style="list-style-type: none"> ➤ Loses its cutting ability due to poor wear resistance.

- Abrasives for USM are generally available in grit sizes ranging from 240 - 1000.

Grade	Grit size	Application
Coarse grits	200 - 400	Roughing work
Finer grits	800 - 1000	Finishing work
Extremely fine grits	1200 - 2000	Fine Finishing work (Where extreme accuracy is demanded)

- Selection of abrasives depends on hardness, usable life, cost and particle size.
- Fresh abrasives are preferred because of their good cutting ability and to sustain the removal rate.

Carrier Fluids

- The abrasive material is mixed with water (Carrier Fluid) to form an abrasive slurry.
- The most common abrasive concentration is water with 30 – 40 % by volume of the abrasives.
- The thinner mixtures are used to promote efficient flow when drilling holes or when forming complex cavities.
- The abrasive slurry should be replaced periodically.
- When water is used as a carrier fluid, some inhibitors are added to the water to improve its performance.

Notes : Other carrier fluids used are Benzene, Glycerol and some low viscosity oils.

Characteristics of carrier fluids

- Density approximately equal to that of the abrasives.
- Good wetting characteristics.
- High thermal conductivity and specific heat for efficient heat removal from the cutting area.
- Should have low viscosity.
- Should be non-toxic and easily available at cheap rate.
- Should be non-corrosive.

Functions of carrier fluid in USM

- Acts as an acoustic bond between the work piece and the tool.
- Acts as a coolant.
- Helps efficient transfer of energy.
- Acts as medium to carry the abrasive, machined materials and worn abrasives.

5. Abrasive feed mechanism

- Abrasive slurry is supplied through a nozzle by a pump. A good method is to keep the tool and the work piece in a bath of slurry.
- This ensures good supply of slurry and reduces any tendency of the tool to scatter the slurry when the amplitude is large.
- Another efficient method is to supply the slurry to the cutting zone through a hollow tool or through holes in the work piece.

6. Tool feed mechanism

- The objective of the tool feed mechanism is to apply the static load between the tool and the workpiece, during machining operation.
- It also brings the tool slowly, close to the workpiece surface and provides adequate, constant cutting force, then aids for the return of the tool as when desired. The sensitivity of feed is very important.
- Feed may either be given to the acoustic head or to the work piece, but in general feed motion is given to the acoustic head so as to facilitate positioning of the workpiece in X-Y direction.
- The tool feed mechanism controls the penetration rate and the depth of machining.

Functions of tool feed mechanism :

1. Bring the tool close to the workpiece, giving place for abrasive flow.
2. To provide the required impact force or cutting force and maintain throughout the operation as required.
3. Return the tool smoothly without damaging the cavity produced.

Types of feed mechanism

- | | |
|----------------|---------------------------------|
| 1. Spring type | 2. Counter-weight type |
| 3. Motor type | 4. Pneumatic and hydraulic type |

1. Spring type feed mechanism

- In this mechanism spring pressure is used to feed the tool during machining operation. This type of mechanism is preferred for its sensitivity and compactness.

2. Counter-weight type feed mechanism

- This mechanism is also called **Gravity feed** mechanism.
- In this mechanism, counter weight are used to apply the load to the head through a pulley as shown in Fig. 1.25(a) In order to reduce the friction, ball bearing are used.
- This mechanism is preferred for its simple construction. The force can be adjusted by varying the counter weights.
- This type is insensitive and inconvenient for adjustability during the operation.

3. Pneumatic and hydraulic type feed mechanism

- This is used for high rating machines. In order to get high feed rate, pneumatic feed mechanism is used.
- All the above types are provided with a tool displacement reading arrangement to know about the depth of penetration.

Working Principle

- When an AC power supply is given to the transducer, due to excitation, the transducer vibrates and the vibration is amplified by the horn or concentrator.
- The amplitude of vibration is maximum at the end of the tool holder where the tool is attached. The tool vibrates at the maximum frequency.

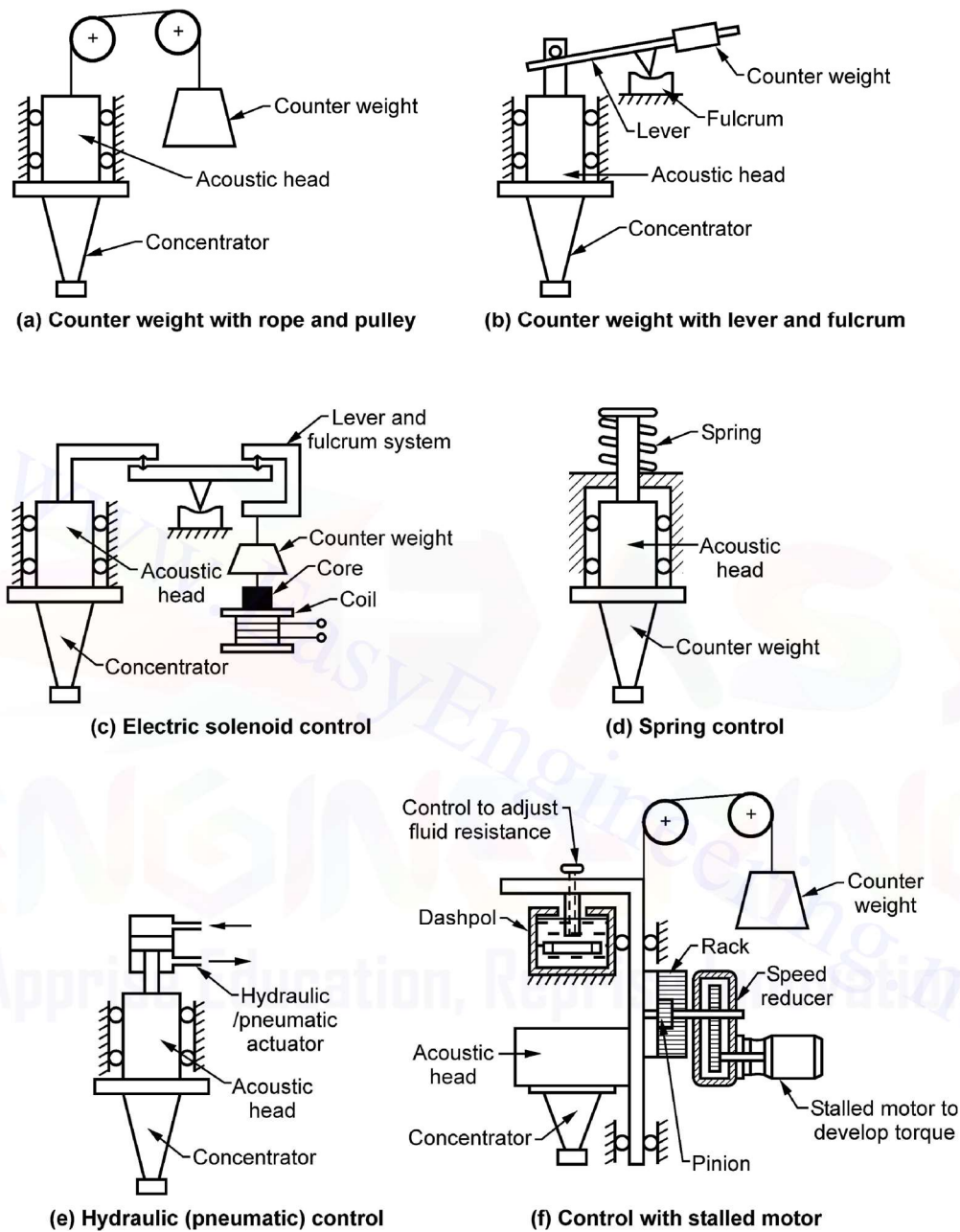

Fig. 1.25 Different types of feeding arrangements for USM

- The tool is fed on to the workpiece surface along with the supply of abrasive slurry. As the tool during vibration goes up and comes down, the abrasive particles entrapped between the tool and the workpiece surface are given impact on the workpiece surface.

- This impact causes the fracture and the particles are carried away by the circulating slurry of abrasive. Since the tool is the mirror image of the cavity to be produced, the tool feed mechanism aids for the formation of the cavity to the required shape.

Work Material

- Material removal method involved in this process is brittle fracture and obviously works only on relatively brittle materials.
- Any hard materials like stones, carbides, ceramics and brittle materials can also be machined.
- Any materials having high hardness >50 HRC like stainless steel, germanium, glass, ceramics etc., can be machined.

Mechanism and Material Removal

- In ultrasonic machining an abrasive slurry is pumped between tool and work, and the tool is given a high frequency, low amplitude oscillation, which in turn, transmits a high velocity to fine abrasive particles which are driven against the workpiece.
- At each stroke, minute chips of material are removed by fracture or erosion. Material Removal Mechanism involves both fracture and plastic deformation by impact of grains due to vibrating tool.

1.13.1 Process Variables of USM

1. Effect of amplitude and frequency of vibration on MRR

- Different researchers have different predictions on the effect of amplitude on MRR.
 - Rozenberg found that for a given material, the MRR is proportional to the square of the amplitude.
 - Miller has shown that the cutting rate bears a linear relationship with amplitude. According to him the MRR increase in amplitude and frequency.
 - Shaw showed that MRR is proportional to amplitude $3/4$. He also predicted that the MRR is directly proportional to the first power of frequency for a fixed amplitude.
- Increases in frequency increases the number of blows on the grain particles impinging on the workpiece surface. So the MRR increases almost linearly with frequency.

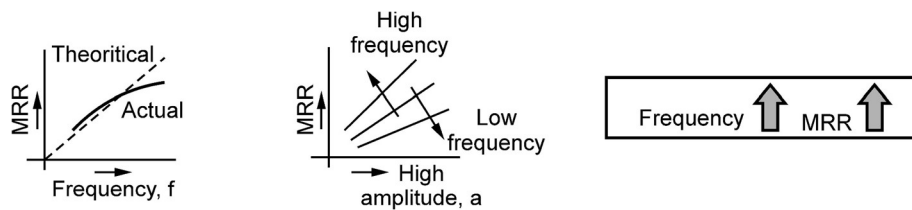

Fig. 1.26

2. Effect of particle velocity

- Markov has shown that the MRR is directly proportional to the particle velocity. So particle velocity increases the number of particles per impinging per unit time also increases.



3. Effect of static loading or feed force

- The MRR increases with an increase in the feed force. But it tends to decrease beyond a critical value of the force, since the magnitude of the force crushes the abrasive grains thus decreasing its cutting ability and the MRR.
- As the feed force is more, the surface finish is good, because the grains are crushed to smaller size.

4. Effect of grain size

- As the grain size increases MRR also increases proportionally. However Grain size increases the MRR also increases till the grain size equals the amplitude of vibration. Beyond this, the MRR decreases due to effect of crushing of grains.

5. Effect of hardness ratio

- The ratio of workpiece hardness to tool hardness affects the MRR significantly in a way that as the ratio increases the MRR decreases according to the trend shown in graph.
- The Brittle materials are machined more rapidly than the ductile materials.

6. Effect of grain size (Grain diameter)

- Regarding the surface finish, when the grain size increases the surface roughness also increases and vice versa.
- Grain size also affects the accuracy of the cavity to be produced. Normally the hole is cut larger than the size of the tool owing to the flow of abrasive slurry along the sides and bottom of the tool.

7. Effect of viscosity

- The MRR drops appreciably when the viscosity increases, because the increase in viscosity tends to dampen the oscillations of the grains, thus decreasing the energy provided on the workpiece.

8. Effect of abrasive slurry concentration

- The abrasive slurry should flow easily under the gap between the tool and the workpiece surface.
- The slurry concentration directly controls the number of grains producing impact and the magnitude of the impact.
- The concentration increases the MRR also increases. The trend of increase in the number of grain for the unit volume of liquid media disturbing the power of impact to all the grains.

1.13.2 Process Capability

1. Can machine work piece harder than 40 HRC to 60 HRC like carbides, ceramics, tungsten glass that cannot be machined by conventional methods
2. Tolerance range 7 micron to 25 microns
3. Holes up to 76 micron have been drilled hole depth upto 51mm have been achieved easily. Hole depth of 152 mm deep is achieved by special flushing techniques.
4. Aspect ratio 40:1 has been achieved
5. Linear material removal rate – 0.025 to 25 mm/min
6. Surface finish – 0.25 micron to 0.75 micron
7. Non directional surface texture is possible compared to conventional grinding
8. Radial over cut may be as low as 1.5 to 4 times the mean abrasive grain size.

Material removal models in USM

Theoretical analysis and experimental results have revealed that USM is a form of abrasion and material removal in the form of small grains by four mechanisms

1. Throwing of abrasive grains
2. Hammering of abrasive grains
3. Cavitation's in the fluid medium arising out of ultrasonic vibration of tool.
4. Chemical erosion due to micro – agitation

Material removal due to throwing and hammering is significant and MR due to cavitation and chemical erosion can be ignored. Abrasive particles are assumed to be spherical in shape having diameter (d_g). Abrasive particles move under high frequency vibrating tool.

There are two possibilities when the tool hit the particle.

- If the size of the particle is small and gap between the tool and work is large, then particle will be thrown by tool to hit the work piece.
- If the size of the particle is large and gap between tool and work is small, then particle is hammered over the work surface.

Advantages

1. It can be used machine hard, brittle, fragile and non-conductive material.
2. No heat is generated in work, therefore no significant changes in physical structure of work material.
3. Non-metal (because of the poor electrical conductivity) that cannot be machined by EDM and ECM can very well be machined by USM.
4. It is burr less and distortion less processes.
5. Capability of drilling circular, no-circular holes in very hard materials like stones, carbides, ceramics and exceptionally brittle materials.
6. Bur less process.
7. No thermal effects on the machined workpiece.
8. Low cost of metal removal.
9. It can be adopted in conjunction with other new technologies like EDM, ECG, and ECM.
10. Equipment is safe to operate.

Disadvantages

1. Low metal removal rate. Not suitable for heavy stock removal.
2. It is difficult to drill deep holes, as slurry movement is restricted.
3. Tool wear rate is high due to abrasive particles. Tools made from brass, tungsten carbide, MS or tool steel will wear from the action of abrasive grit with a ratio that ranges from 1:1 to 200:1
4. USM can be used only when the hardness of work is more than 45 HRC.
5. Frequent tuning is required.
6. Not economical for soft materials.

Limitations

1. Low MRR
2. Depth of cylindrical holes produced is limited by the abrasive transport system.
3. High tooling cost.
4. Periodic replacement of abrasive slurry.
5. Tendency of tools to 'break out' at the bottom owing to static load and amplitude.
6. Inability to machine soft material.

Applications

1. Machining of cavities in electrically non-conductive ceramics
2. Diamond, tungsten, tungsten carbide, gem stones and synthetic ruby can be successfully machined.
3. Used to machine fragile components.
4. Used for multistep processing for fabricating silicon nitride (Si_3N_4) turbine blades
5. Large number of holes of small diameter. 930 holes with 0.32 mm has been reported (Benedict, 1973) using hypodermic needles
6. Used for machining hard, brittle metallic alloys, semiconductors, glass, ceramics, carbides etc.
7. Used for machining round, square, irregular shaped holes and surface impressions.
8. Used in machining of dies for wire drawing, punching and blanking operation
9. USM can perform machining operations like drilling, grinding and milling operations on all materials which can be treated suitably with abrasives.
10. USM has been used for piercing of dies and for parting off and blanking operations.
11. USM enables a dentist to drill a hole of any shape on teeth without any pain
12. Ferrites and steel parts, precision mineral stones can be machined using USM
13. USM can be used to cut industrial diamonds
14. USM is used for grinding Quartz, Glass, ceramics, Cutting holes with curved or spiral centre lines and cutting threads in glass and mineral or metallic-ceramics
15. Gang drilling can be done by employing USM process.

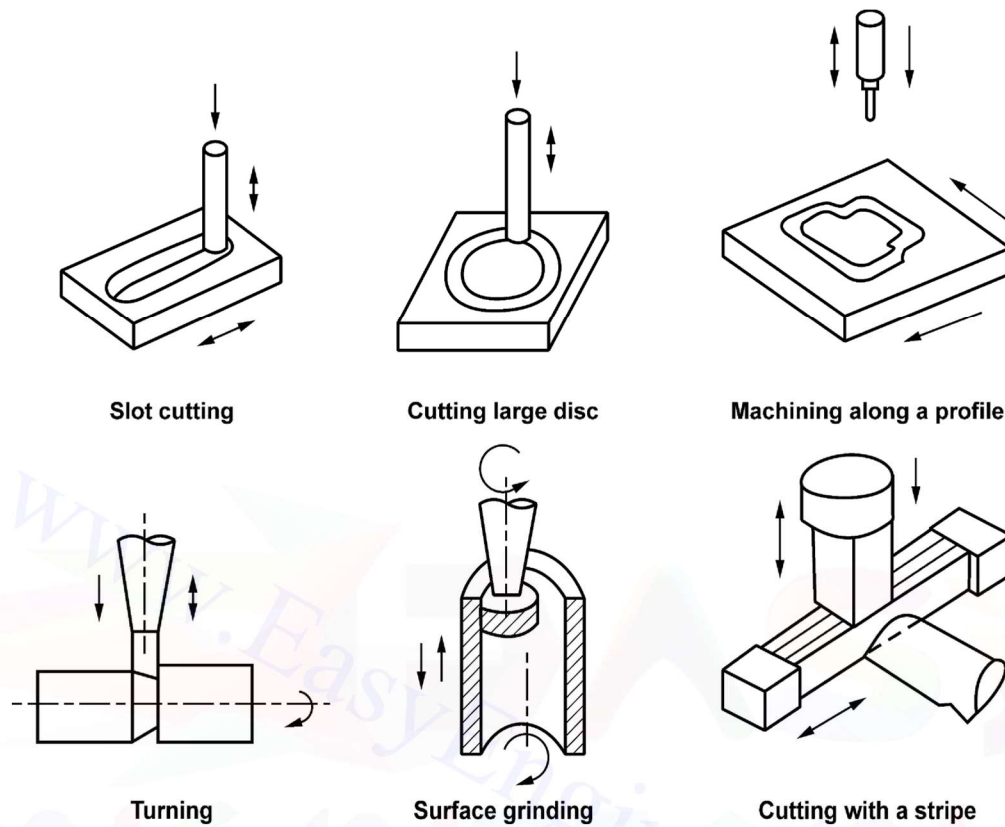

Fig. 1.27 Some applications of USM

1.14 Two Marks Questions with Answers

Part - A

Q.1 What are the characteristics of unconventional machining process? (Section 1.1.1)

Q.2 List the unconventional machining process, which uses mechanical energy.

Ans. :

- Abrasive Jet Machining
- Abrasive Water Jet Machining
- Water Jet Machining
- Ultrasonic Machining.

Q.3 What is the necessity for UCMP? (Section 1.1.2)

Q.4 How non-traditional machining processes are classified. (Section 1.3)

Q.5 What are the importances of UCMP? (Section 1.1.2)

Q.6 Explain the classification of UCMP according to major energy source employed. (Section 1.3)

Q.7 Distinguish traditional and non-traditional machining process. (Section 1.2)

Q.8 What types of energy are employed in non-traditional machining process ? (Section 1.4)

Q.9 Enlist the requirement that demands the use of advanced machining process. (Section 1.1.2)

Q.10 Why unconventional machining process is not so effective on soft materials like Aluminium?

Ans. : Unconventional machining process is not so effective on soft metals like aluminium, because accuracy cannot be maintained due to more metal removal rate.

Q.11 How will you compare various non-traditional processes ? (Section 1.3.1)

Q.12 What are the different machining characteristics with respect to which the non traditional machining process can be analysed ?

Ans. : Material removal rate, accuracy, surface finish, cutting speed, feed, depth of cut

Q.13 What are the industrial needs for unconventional machining processes ?

Ans. : To machine high steel alloys.

To generate desired complex surfaces and.

To achieve high accuracy and surface finish.

Q.14 Write down the energy transfer media, energy source and mechanism of metal removal for the following process.

Ans. : a) Water Jet Machining b) Electrochemical Grinding.

Processes	Energy transfer media	Energy source	Mechanism of metal removal
Water Jet Machining	High velocity water jet	Hydraulic pressure	Erosion
Electrochemical Grinding.	Electrolyte	Electrical source and mechanical movement	Ion displacement

Q.15 Name the important factors that should be considered during the selection of an unconventional machining process for a given job.

Ans. :

- i) Physical parameters
- ii) Shapes to be machined
- iii) Process capability or machining characteristics
- iv) Economic considerations.

Q.16 Classify modern machining process on the basis of the type of energy employed. mechanical, thermal, chemical and electrochemical.

Q.17 Mention thermal energy based unconventional machining process. laser beam machining, plasma arc machining, electron beam machining.

Q.18 What are the advantages of unconventional machining processes ?

Ans. : • High accuracy and surface finish.
• No direct contact of tool and workpiece, so there is less/no wear.
• Quieter operation.

Q.19 List the unconventional machining process based on chemical energy

Ans. : Chemical Machining, Electro Chemical machining, Electro Chemical Grinding

Q.20 Suggest a suitable unconventional machining process to cut a thin glass plate into two pieces.

Ans. : Process like ECM, EDM, PAM, EBM are ruled out because they are suitable to machine only electrically materials

WJM, AWJM, USM can be used for machining.

Based on accuracy required any one process can be selected.

Q.21 What is the transfer medium in AJM ?

Ans. : High velocity particles.

Q.22 Write the applications of AJM. (Section 1.10.2)

Q.23 List any four variables in AJM that influence the MRR.

Ans. : Carrier Gas, Jet Velocity, Stand of distance, mixing ratio.

Q.24 What are the various abrasives used in AJM process ?

Ans. : Uniform particles of sand, steel grit, copper slag, walnut shells, and powdered **abrasives** are **used**.

Q.25 Why abrasive jet machining process is not recommended to machine ductile materials.

Ans. : While machining ductile materials by AJM, the hard abrasive grits may get embedded on the soft machined surface. This obstructs cut quality as well as properties and appearance of machined surface.

Q.26 Write the formula for MRR for ductile and brittle materials in AJM.

Ans. :

$$\therefore \text{MRR}_{\text{brittle}} = 1.04 \frac{M_g \cdot U^{3/2}}{\rho_g^{1/4} \cdot H^{3/4}}$$

$$\therefore \text{MRR}_{\text{ductile}} = 0.5 \frac{M_g U^2}{H}$$

U = Velocity of abrasive jet at the point of impact.

H = Flow strength or hardness of the work material.

M_g = Mass flow rate of abrasive particles.

ρ_g = Density of each abrasive particle.

Q.27 Reuse of abrasives is not recommended in AJM process. Why ?

Ans. : Reuse of abrasives is not recommended since the cutting ability of **abrasive** decrease after the usage and also the contamination of wear materials clogging the nozzle and the cutting unit orifice.

Q.28 What is the principle of WJM ? (Section 1.12 (Principle))

Q.29 List the applications of WJM. (Section 1.12.1 (Applications))

Q.30 List the process parameters of WJM.

Ans. : Jet Nozzle, jet Fluid, Workpiece

Q.31 Mention the application of catcher in water jet machining.

Ans. : Acts as a reservoir for collecting the machining debris entrained in the water jet. Moreover, it reduces the noise levels associated with the reduction in the velocity of the water jet.

Q.32 List out the limitations of WJM process.

Ans. : Very thick parts cannot be machined.

It is not suitable for mass production because of high maintenance requirements.

Q.33 Write the typical applications of ultrasonic machining.

Ans. : • **Machining** very precise and intricate shaped articles.

- Drilling the round holes of any shape.
- Grinding the brittle materials.
- Profiling the holes.
- Engraving.
- Trepaning and coining.

Q.34 What is the effect of abrasive grain size on machining rate in USM ?
(Section 1.13.1 (Point no. 6))

Q.35 What is the need for transducer in USM ?

Ans. : The transducer, which generates the ultrasonic vibration based on piezoelectric effect.

It converts electrical energy to mechanical vibrations.

Q.36 State the working principle of USM. (Section 1.13 (Working))

Q.37 List the applications of USM ? (Section 1.13.1(Applications))

Q.38 List the process parameters of USM.

Ans. : Effect of particle velocity
Effect of grain size

Effect of hardness ratio

Effect of viscosity.

Q.39 List out the abrasive materials used in ultrasonic machining process.

Ans. : Silicon Carbide, Aluminium Oxide, Boron Carbide

Q.40 What are the advantages of ultrasonic machining? (Section 1.13.2 (Advantages))

1.15 Long Answered Questions

Part - B

- Q.1** Compare the mechanical and electrical energy processes in terms of physical parameters, shape capabilities, process capability and process economy. (Section 1.3.1)
- Q.2** Explain the reasons for the development of UCMP. Discuss about the criteria recommended in selection of these processes. (Sections 1.1.2 and 1.4.4)
- Q.3** i) Explain the factors that should be considered during the selection of an appropriate unconventional machining process for a given job. (Section 1.8)
ii) Compare and contrast the various unconventional machining process on the basis of the type of energy employed, material removal rate, transfer media and economical aspects. (Section 1.4.4)
- Q.4** Make a comparison between traditional and unconventional machining processes in terms of cost, application, scope, machining time, advantages and limitations. (Section 1.2)
- Q.5** For different non-conventional processes, present in the form of table, various process parameters recommended. (Section 1.8)
- Q.6** How will you analyse the applicability of different processes to different types of materials, namely metals, alloys and non-metals? Presentation in the form of table is preferred. (Section 1.5.3)
- Q.7** What are the basic limitations of conventional manufacturing process? Justify the need of unconventional machining process in today's industries. (Sections 1.1 & 1.1.1)
- Q.8** Explain the principle of working of the AJM process with its advantages, disadvantages, limitations and applications. (Sections 1.10 and 1.10)
- Q.9** With a neat sketch explain the operation and effect of process parameters of AJM. List the applications. (Sec 1.10.2 (Process Parameter))
- Q.10** Explain the principle of AJM. Mention some of the specific applications. Discuss in detail about the AJM process variables that influence the rate of material removal and accuracy in the machining. (Sections 1.10 and 1.10.2)
- Q.11** Write the names of various elements of Abrasive Jet Machining (AJM) and explain them in brief. (Sec 1.10 (Equipment))

- Q.12** Compare the types of nozzle design employed in AWJM with neat sketches. **(Fig 1.11)**
- Q.13** Describe the process parameters of abrasive Jet machining along with the effect of all the process parameters. **(Section 1.10.2)**
- Q.14** Explain the different applications and process control features of WJM. Describe the principle and equipment for WJM. **(Section 1.12)**
- Q.15** Discuss the process parameters in WJM process. **(Section 1.12.1)**
- Q.16** List the application and limitation of WJM. **(Section 1.12.1 (Application and Limitations))**
- Q.17** Explain the principle of Ultrasonic Machining (USM) and its equipment. Explain the factors which influence the Metal Removal Rate (MRR) in USM. **(Sections 1.13 and 1.13.1)**
- Q.18** Explain the following in detail.
- a. Types of Transducers for USM **(Section 1.13 (Transducer))**
 - b. Feed Mechanisms in USM. **(Section 1.13 (Types of feed mechanism))**
 - c. Typical Applications of USM. **(Section 1.13.2 (Applications))**
 - d. Abrasives for USM. **(Section 1.13 (Abrasive Slurry))**
- Q.19** List the various types of tool holders and transducers used in ultrasonic machining and explain them briefly. **(Section 1.13 (Transducer), Section 1.13 (Types of feed mechanism))**
- Q.20** Discuss the effects of the following parameters on the MRR and surface finish in USM. **(Section 1.13.1)**
- a. Amplitude and frequency
 - b. Abrasive rates
 - c. Concentration of abrasives
 - d. Material hardness.
- Q.21** Explain the USM machine Set-up and discuss various feed mechanisms. **(Section 1.13 (Types of feed mechanism))**
- Q.22** Explain the principle of USM with neat diagram. **(Section 1.13)**
- Q.23** List the commonly used abrasive powder for the tooling of USM and their properties. **(Section 1.13 (Abrasive Slurry))**
- Q.24** Discuss in detail about the methods of generating the ultrasonic, characteristics of the various types of tool holder and tool feed mechanisms in USM. **(Section 1.13)**
- Q.25** Compare USM, WJM and AJM in terms of process capabilities and limitations. **(Section 1.5.2)**
- Q.26** How are ultrasonic vibrations generated in USM process? **(Section 1.13)**

Introduction and Mechanical Energy Based Processes

Q.10 Vacuum is the machining medium for _____.

- a LBM b WJM
 c EBM d none of the mentioned

[Ans. : a]

Q.11 In chemical machining is material removal takes by ?

- a Chemical reaction b Erosion
 c Electron removal d None of the mentioned

[Ans. : a]

Q.12 Which of the following is an example of hybrid machining ?

- a Ultrasonic Machining b Electron Beam Machining
 c Ultrasonic assisted electrochemical machining
 d Laser Beam Machining

[Ans. : c]

ABRASIVE JET MACHINING

Q.13 In advanced machining processes, what is the full form of AJM ?

- a Automatic Jet Manufacturing b Abrasive Jet Machining
 c Automated Jet Machining d Abrasive Jet Manufacturing

[Ans. : b]

Q.14 In AJM, which of the following materials are used as abrasive grains ?

- a Al_2O_3 b SiC
 c Glass beads d All of the mentioned

[Ans. : d]

Q.15 In abrasive jet machining, work piece material is removed by which of the following means ?

- a Vaporization b Electro plating
 c Mechanical abrasion d Corrosion

[Ans. : c]

Q.16 Which type of materials can be machined using abrasive jet machining ?

- a Glass b Ceramics
 c Hard materials d All of the mentioned

[Ans. : d]

Q.17 In machining system of AJM, which is the medium of carrying the abrasive grains for machining ?

- a Liquids b Gases
 c Any fluids d None of the mentioned

[Ans. : b]

Q.18 In machining system of AJM, what is/are the gas/es used for carrying the abrasives?

- a CO_2 b Air
 c Nitrogen d All of the mentioned

[Ans. : d]

Introduction and Mechanical Energy Based Processes

Q.19 What is the pressure of gas that is to be supplied, for carrying the abrasives ?

a 0.1 to 1.0 kg/cm²

b 2.0 to 8.0 kg /cm²

c 10.0 to 18.0 kg/cm²

d 25.0 to 35.5 kg/cm²

[Ans. : b]

Q.20 Which of the following gas, should never be used as the carrier of abrasives ?

a Nitrogen

b CO₂

c Oxygen

d Air

[Ans. : c]

Q.21 What is the frequency of mixing chamber, consisting of gas and abrasives ?

a 10 Hz

b 30 Hz

c 50 Hz

d 70 Hz

[Ans. : c]

Q.22 In abrasive jet machining, what may be the size of the abrasive grains used ?

a 10 - 40 μm

b 50 - 100 μm

c 100 - 150 μm

d 200 - 300 μm

[Ans. : a]

Q.23 What are the processes where abrasive jet machining can be used ?

a Cleaning

b Cutting

c Deburring

d All of the mentioned

[Ans. : d]

Q.24 State whether the following statement is true or false.

“In Abrasive jet machining, commercial grades powders can be used for machining.”

a True

b False

[Ans. : b]

Q.25 In machining system of AJM, which of the following controls the relative motion between work piece and nozzle ?

a Cam drives

b Pantographs

c Trace mechanisms

d All of the mentioned

[Ans. : d]

Q.26 Masks, which are used to confine the jet stream location on work piece are made of, which type of materials ?

a Copper

b Glass

c Rubber

d All of the mentioned

[Ans. : d]

Q.27 In AJM, what is the mechanism of removal of material from the work piece ?

a Corrosion

b Abrasion

c Electron transfer

d Vaporization

[Ans. : b]

Q.28 In AJM, abrasive jet from the nozzle follows, which type of path for a short distance ?

a Parallel

b Inclined

c Perpendicular

d None of the mentioned

[Ans. : a]

Introduction and Mechanical Energy Based Processes

c 10 - 15 hrs d 25 - 40 hrs [Ans. : c]

Q.39 In AJM, what is the life of synthetic sapphire material nozzle ?

a 100 hrs b 300 hrs
 c 500 hrs d 700 hrs [Ans. : b]

Q.40 What are the tolerance limit values in abrasive water jet machining ?

a ± 0.01 mm b ± 0.03 mm
 c ± 0.05 mm d ± 0.07 mm [Ans. : c]

Q.41 In AJM, surface roughness value will vary between which values ?

a $0.01 - 0.10 \mu\text{m}$ b $0.15 - 1.5 \mu\text{m}$
 c $2.0 - 5.0 \mu\text{m}$ d $7.0 - 10.0 \mu\text{m}$ [Ans. : b]

Q.42 Which of the following, are the processes and applications in which abrasive jet machining can be applied ?

a Drilling b Cutting
 c Deburring d All of the mentioned [Ans. : d]

Q.43 Using abrasive jet machining, wire cleaning and insulation stripping take place without affecting the conductor.

a True b False [Ans. : a]

Q.44 In abrasive jet machining, intricate shapes and holes are machined on which type of materials ?

a Brittle b Thin
 c Difficult to machine d All of the mentioned [Ans. : d]

Q.45 State whether the following statement is true or false, about abrasive jet machining.

"Using abrasive jet machining, micro deburring of hypodermic needles can take place."

a True b False [Ans. : a]

Q.46 What are the type of materials that can be machined using abrasive jet machining ?

a Glass b Sapphire
 c Quartz d All of the mentioned [Ans. : d]

Q.47 What is the amount of material utilizes when we machine parts using Abrasive jet machining ?

a Very low b Low
 c Medium d High [Ans. : d]

Introduction and Mechanical Energy Based Processes

Q.57 What is the general power rating of the hydraulic pump, used in WJM ?

a 10 kW

b 20 kW

c 30 kW

d 40 kW

[Ans. : c]

Q.58 Which of the following are the components of intensifier present in water jet machining system ?

a Piston

b Plunger

c Limit switch

d All of the mentioned

[Ans. : d]

Q.59 Intensifier increases the pressure water by which of the following values ?

a 10 - 100 MPa

b 100 - 200 MPa

c 200 - 400 MPa

d 400 - 1000 MPa

[Ans. : c]

Q.60 On which property of water, will the accumulator in water jet machining rely on ?

a Density

b Compressibility

c Viscosity

d Velocity

[Ans. : b]

Q.61 What are the values of typical tube diameters in the machining system in WJM ?

a 0.1 to 1 mm

b 1 to 6 mm

c 6 to 14 mm

d 14 to 25 mm

[Ans. : c]

Q.62 What is the expected life of the nozzles used in WJM ?

a 10 hrs

b 20 hrs

c 100 hrs

d 200 hrs

[Ans. : d]

Q.63 Which of the following does not damage the nozzle used in Water jet machining ?

a Particles of dirt

b Mineral deposits

c Water

d All of the mentioned

[Ans. : c]

Q.64 What are the uses of catcher in machining system of water jet machining ?

a Collecting dirt

b Collection of debris

c Reduce noise levels

d All of the mentioned

[Ans. : d]

Q.65 Distance between which components, is the stand-off distance ?

a Nozzle-inlet and work piece top

b Nozzle-outlet and work piece-top

c Nozzle-inlet and work piece-bottom

d Nozzle-outlet and work piece-bottom

[Ans. : b]

Q.66 What is the value of diameter of the jet cutting nozzle in WJM ?

a 0.01 - 0.1 mm

b 0.1 - 0.3 mm

c 0.3 - 0.7 mm

d 0.7 - 1.5 mm

[Ans. : b]

Introduction and Mechanical Energy Based Processes

Q.97 The introduction of compressed air to the water jet enhances the deburring action.

a True

b False

[Ans. : a]

Q.98 What is the grain size of abrasive particles, which are often used for Abrasive water jet machining ?

a 0.01 - 0.50 μm

b 10 - 150 μm

c 200 - 500 μm

d 500 - 1000 μm

[Ans. : b]

Q.99 How is the material removed in abrasive water jet machining ?

a Vaporization

b Electron transfer

c Corrosion

d Erosion

[Ans. : d]

Q.100 Which of the following is not the feed mechanism of the abrasives in AWJM ?

a Side feed

b Cross feed

c Central feed

d All of the mentioned

[Ans. : b]

Q.101 In Abrasive water jet machining, how are the abrasives fed into the water jet stream ?

a Suspension

b Injection

c All of the mentioned

d None of the mentioned

[Ans. : c]

Q.102 What is the use of delivery system in the machining system of AWJM ?

a To deliver colloidal solution

b To pump water

c To fed abrasives

d None of the mentioned

[Ans. : b]

Q.103 Of the following components, which one does not come under the machining system of AWJM ?

a Water delivery system

b Transducer

c Cutting nozzles

d Mixing chambers

[Ans. : b]

Q.104 In abrasive water jet machining, intensifier is used to deliver which type of pressure ?

a Very low pressure

b Low pressure

c Medium pressure

d High pressure

[Ans. : d]

Q.105 In mixing chamber of AWJM, which of the following are mixed ?

a Abrasives and colloidal solution

b Abrasives and water jet

c Colloidal and water jet

d None of the mentioned

[Ans. : b]

Q.106 Of the following, which one is a type of suspension in AWJM ?

a Direct pumping

b Indirect pumping

c Bypass pumping

d All of the mentioned

[Ans. : d]

Introduction and Mechanical Energy Based Processes

Q.107 In machining system of AWJM, mixing chamber is immediately followed by which of the following component ?

a Focusing tube

b Cutting nozzle

c Intensifier

d Water delivery

[Ans. : a]

Q.108 Which of the following energies are absorbed using the catchers in Abrasive water jet machining ?

a Pressure energy

b Kinetic energy of abrasives

c Residual energy

d All of the mentioned

[Ans. : c]

Q.109 Which of the following are different types of catchers used in AWJM ?

a Water basin type

b Submerged steel balls type

c TiB₂ type

d All of the mentioned

[Ans. : d]

Q.110 Which of the following is not a process parameter of abrasive water jet machining ?

a Frequency of vibration

b Orifice diameter

c Pressure

d Stand-off distance

[Ans. : a]

Q.111 Which of the following come under the process parameters of the abrasive water jet machining?

a Abrasive size

b Machine impact angle

c Traverse speed

d All of the mentioned

[Ans. : d]

Q.112 What is the value of orifice diameter in abrasive water jet machining ?

a 0.01 - 0.03 mm

b 0.03 - 0.09 mm

c 0.10 - 0.30 mm

d 0.30 - 0.90 mm

[Ans. : c]

Q.113 Of the following values, between which of them pressure value will range ?

a 1000 - 1500 bar

b 1500 - 2500 bar

c 2500 - 4000 bar

d 4000 - 10000 bar

[Ans. : c]

Q.114 When compared to sand, how much effective is garnet as abrasive material in AWJM ?

a 20 %

b 30 %

c 40 %

d 50 %

[Ans. : b]

Q.115 State whether the following statement is true or false about Abrasive water jet machining.

"A material, whose material removal rate is higher, produces larger surface roughness."

a True

b False

[Ans.: a]

Introduction and Mechanical Energy Based Processes

Q.125 USM removes materials using the _____ tool.

- a Perpendicularly rotating b Perpendicularly oscillating
 c Axially oscillating d Inclined oscillating

[Ans. : c]

Q.126 Which is softer material in USM ?

- a Tool b Work piece
 c Tool and work piece d None of the mentioned

[Ans. : a]

Q.127 Frequency of tool's oscillation in USM ranges between _____.

- a 5-10 kHz b 10-15 kHz
 c 18-20 kHz d 25-50 kHz

[Ans. : c]

Q.128 Amplitude of oscillation of tool in USM ranges between _____.

- a 0.1-10 μm b 10-40 μm
 c 50-100 μm d 100-1000 μm

[Ans. : b]

Q.129 In which year, discovery of USM took place ?

- a 1910 b 1925
 c 1943 d 1945

[Ans. : d]

Q.130 The machining system of USM contains which of the following components ?

- a Magnetostrictor b Concentrator
 c Tools and slurry d All of the mentioned

[Ans. : d]

Q.131 In ultrasonic machining, magnetostrictor is energized at ultrasonic frequency.

- a True b False

[Ans. : a]

Q.132 Of the following scientists, who discovered magnetostrictor effect ?

- a Balamuth b Steve O Flower
 c Joule d Turing

[Ans. : c]

Q.133 In ultrasonic machining, magnetostrictor converts magnetic energy into which type of energy ?

- a Mechanical energy b Electrical energy
 c Thermal energy d None of the mentioned

[Ans. : a]

Q.134 What is the value of the amplitude obtained without mechanical amplifier ?

- a 0.0001 - 0.001 μm b 0.001 - 0.1 μm
 c 1 - 10 μm d 10 - 100 μm

[Ans. : b]

Introduction and Mechanical Energy Based Processes

Q.135 What is the value of the amplitude obtained when we use mechanical amplifier ?

a 1 - 10 μm

b 10 - 40 μm

c 40 - 50 μm

d 50 - 100 μm

[Ans. : c]

Q.136 In USM, tool tips must have low resistance and fatigue strength.

a True

b False

[Ans. : b]

Q.137 At what rate slurry is pumped through nozzle in USM ?

a 10 L/min

b 25 L/min

c 50 L/min

d 75 L/min

[Ans. : b]

Q.138 By which of the following means, material is removed in USM ?

a Mechanical abrasion

b Microchipping

c Cavitation

d All of the mentioned

[Ans. : d]

Q.139 What is the percentage of contribution of cavitation to the total material removed ?

a <5%

b 5 - 10 %

c 10 - 20 %

d 20 - 50 %

[Ans. : a]

Q.140 In the following mechanisms, which one is dominant in material removal ?

a Hammering

b Cavitation

c Microchipping

d None of the mentioned

[Ans. : a]

Q.141 When machining porous material, which type of mechanism is introduces ?

a Abrasion

b Erosion

c Corrosion

d Vaporization

[Ans. : b]

Q.142 The rate of material removal depends on which of the following features ?

a Frequency

b Static Pressure

c Machining area

d All of the mentioned

[Ans. : d]

Q.143 The machinability of USM depends on brittleness criterion.

a True

b False

[Ans. : a]

Q.144 Which of the following are the features of tool affecting MRR in USM ?

a Hardness

b Wearability

c Accuracy

d Mounting

[Ans. : d]

Q.145 What is the machinability rate of glass by USM ?

a 25 %

b 50 %

c 75 %

d 100 %

[Ans. : d]

Introduction and Mechanical Energy Based Processes

Q.175 What is the value of depth in ultrasonic sinking, after which, material removal becomes difficult ?

a 1 to 2 mm

b 2 to 5 mm

c 5 to 7 mm

d 7 to 10 mm

[Ans. : c]

Q.176 In production of EDM electrodes, typical ultrasonic speeds, in graphite ranges between ?

a 0.01 - 0.10 cm/min

b 0.10 - 0.25 cm/min

c 0.25 - 0.40 cm/min

d 0.40 - 1.40 cm/min

[Ans. : d]

Q.177 How much is the value of surface finished, achieved using ultrasonic polishing ?

a 0.1 μm

b 0.3 μm

c 0.5 μm

d 0.7 μm

[Ans. : b]

Q.178 In micro-ultrasonic machining, which of the following component vibrates ?

a Tool

b Work piece

c Feed pipe

d All of the mentioned

[Ans. : b]

Q.179 In micro-USM, using WC tool, what is the value of diameter can be achieved ?

a 1 μm

b 3 μm

c 5 μm

d 7 μm

[Ans. : c]

Introduction and Mechanical Energy Based Processes ends