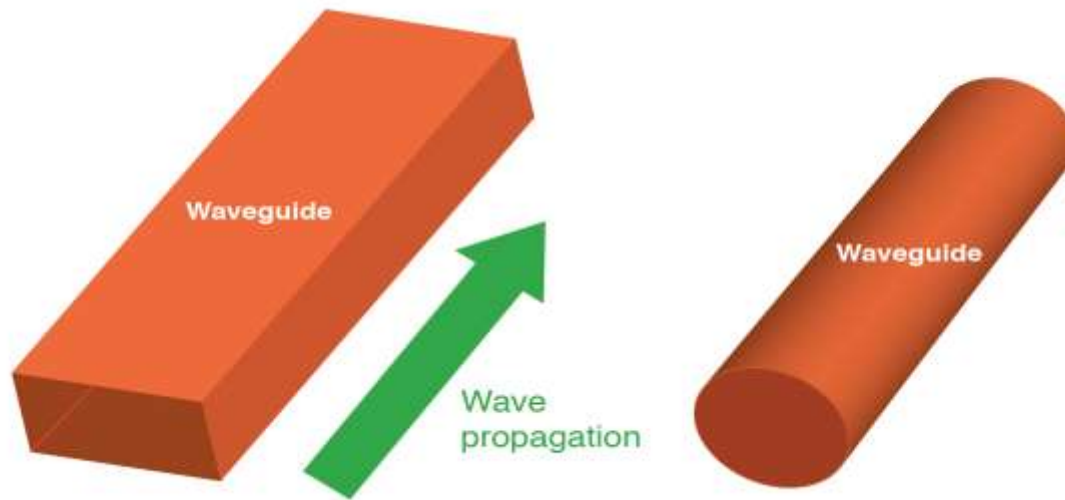


# Waveguides

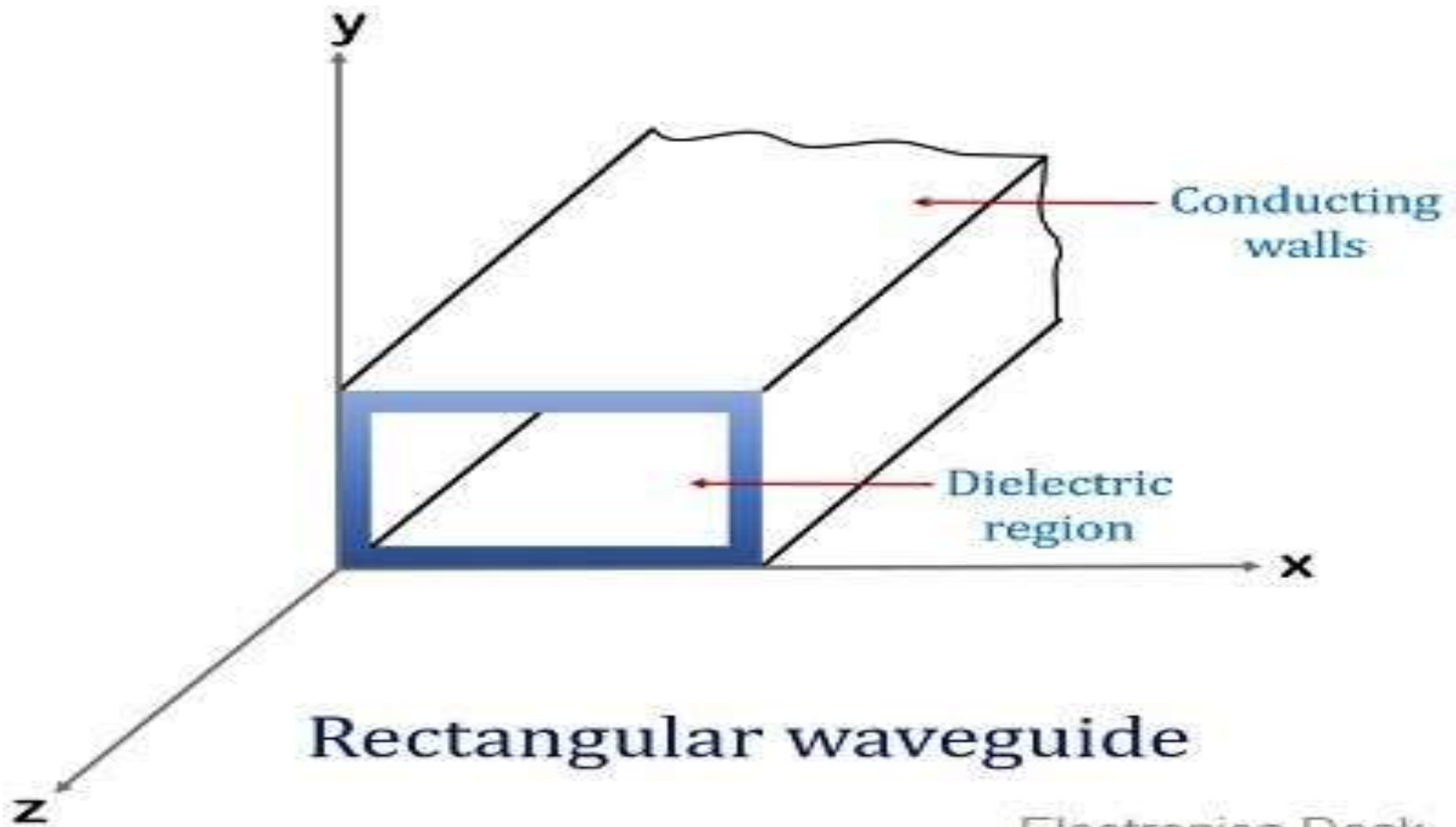
- **Definition:** Waveguides are a special category of “transmission line” that is used to guide (direct) the waves (radiation) along the length of the tube.
- These are typically a hollow metallic tube that acts as the medium to transfer or transmit power.



# Introduction

- In waveguides, the energy is propagated through a tube.
- It can be either rectangular or cylindrical waveguide that does not consist of any central conductor.
- These are basically used for the propagation of electromagnetic energy (microwaves) or signal from an end to another. In the case of low-frequency signal transmission, either parallel transmission lines or coaxial cables are used.
- But in order to have high-frequency signal transmission, waveguides are majorly used.
- The frequency of a microwave signal lies somewhere between 300 MHz to 300 GHz.

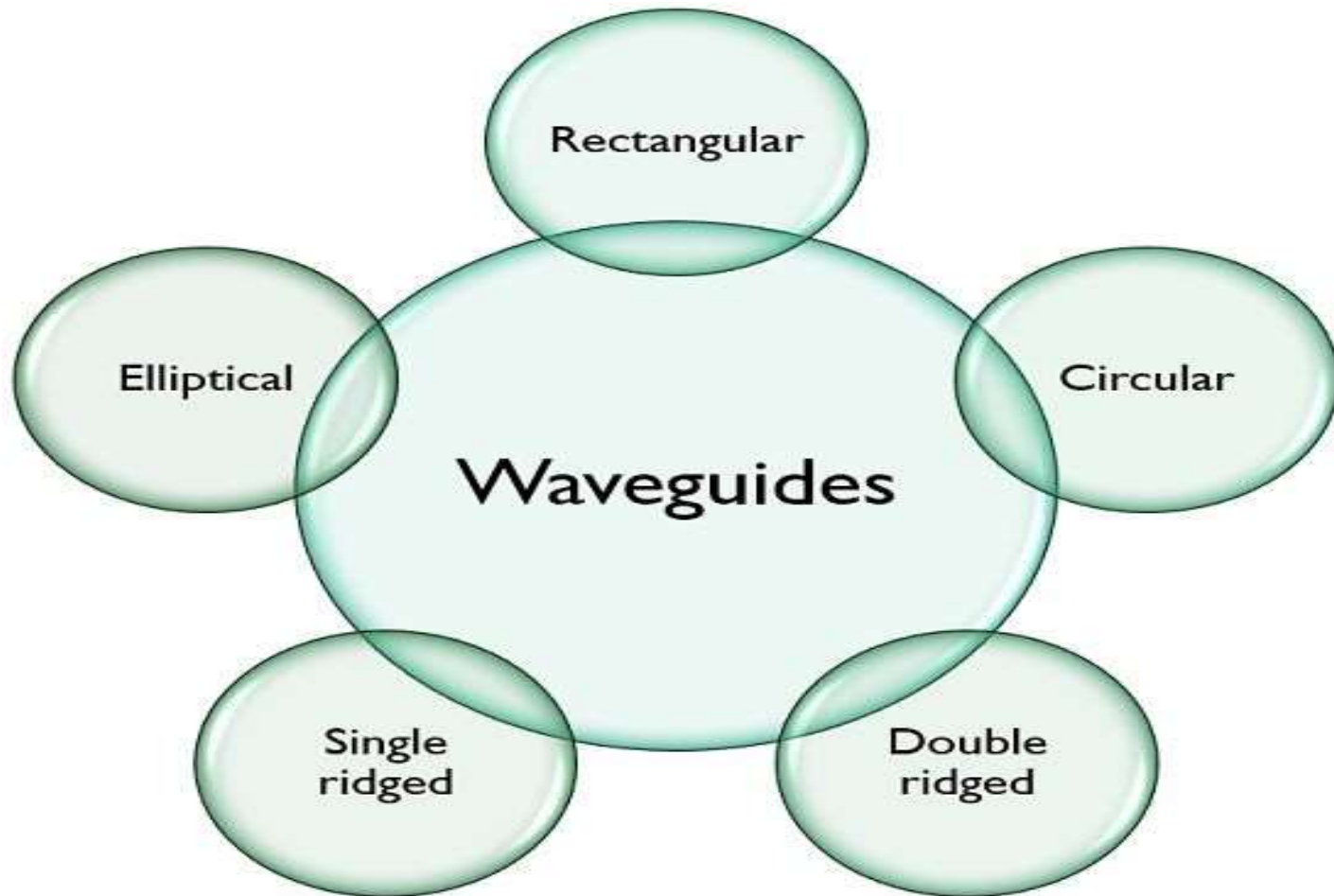
- Waveguides replaced the transmission lines (or coaxial cables) because of more attenuation and dielectric losses were associated with transmission lines.
- As with the help of waveguides, small signal attenuation and large bandwidth can be achieved.
- Waveguides basically function as a high pass filter as it allows the transmission of high-frequency components while attenuating the low-frequency signals.



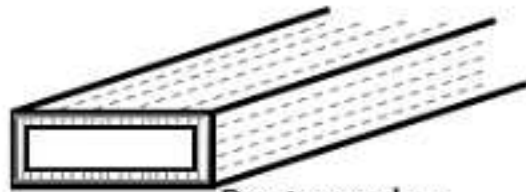
Electronics Desk

- A waveguide transmits a microwave signal by making continuous reflections from the inside walls of the hollow cylindrical tube.
- The walls of the waveguides are generally made up of copper, aluminum, or brass.
- However, its inner surface is coated with gold or silver.

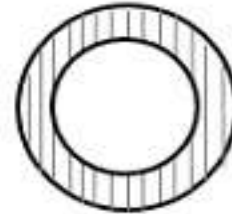
# Types of waveguides



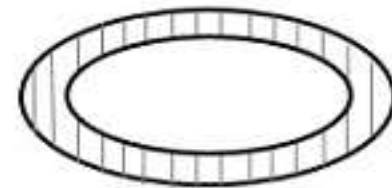
## Types of Waveguides



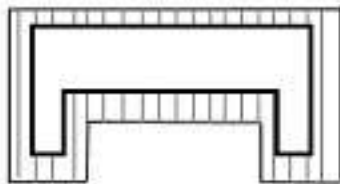
Rectangular  
waveguide



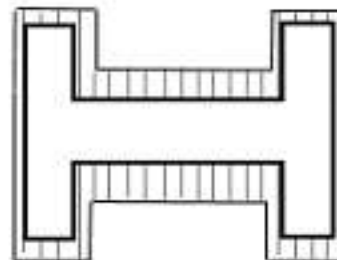
Circular  
waveguide



Elliptical waveguide



Single ridged  
waveguide



Double ridged  
waveguide

- **Characteristics of a Waveguide:**
  - The tube wall provides distributed inductance.
  - The empty space between the tube walls provide distributed capacitance.
  - These are bulky and expensive.
- **Advantages of Waveguides:**
  - Waveguides are easy to manufacture.
  - They can handle very large power in kilowatts
  - Power loss is very negligible in waveguides.
  - They offer very low loss low value of alpha–attenuation
  - When microwave energy travels through waveguide, it experiences lower losses than a coaxial cable.

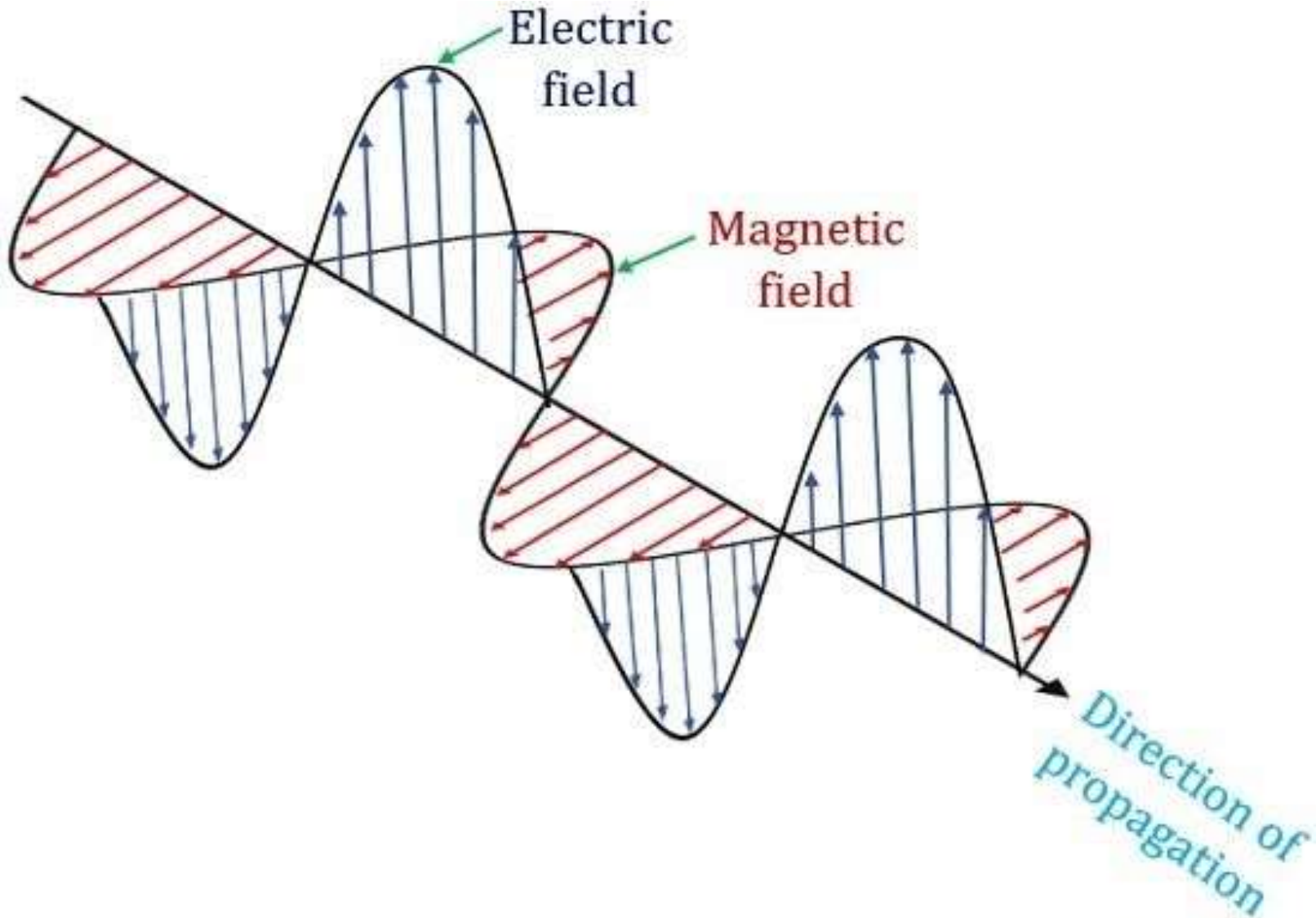
# Transmission Lines Vs Waveguides

- A two conductor structure that **can support a TEM wave** is a transmission line.
- A one conductor structure that **can support a TE wave** or a **TM wave** but not a TEM wave is called as a waveguide.

<b>Transmission Lines</b>	<b>Waveguides</b>
<b>Supports TEM wave</b>	<b>Cannot support TEM wave</b>
<b>All frequencies can pass through</b>	<b>Only the frequencies that are greater than cut-off frequency can pass through</b>
<b>Two conductor transmission</b>	<b>One conductor transmission</b>
<b>Reflections are less</b>	<b>A wave travels through reflections from the walls of the waveguide</b>
<b>It has a characteristic impedance</b>	<b>It has wave impedance</b>
<b>Propagation of waves is according to "Circuit theory"</b>	<b>Propagation of waves is according to "Field theory"</b>
<b>It has a return conductor to earth</b>	<b>Return conductor is not required as the body of the waveguide acts as earth</b>
<b>Bandwidth is not limited</b>	<b>Bandwidth is limited</b>
<b>Waves do not disperse</b>	<b>Waves get dispersed</b>

# Modes of propagation in a Waveguide

- When an electromagnetic wave is transmitted through a waveguide, then it has two field components that oscillate mutually perpendicular to each other.
- Out of the two one is electric field and the other is a magnetic field.
- The propagation of wave inside the waveguide originates basically 2 modes.
- However, overall basically 3 modes exist, which are as follows:



Direction of propagation

Electronics Desk

# Transverse Electric wave

- In this mode of wave propagation, the electric field component is totally transverse to the direction of wave propagation whereas the magnetic field is not totally transverse to the direction of wave propagation.
- It is abbreviated as TE mode.

$$E_z = 0; H_z \neq 0$$

# Transverse Magnetic wave

- In this mode of wave propagation, the magnetic field component is totally transverse to the direction of wave propagation while the electric field is not totally transverse to the direction of wave propagation.
- It is abbreviated as TM mode.

$$E_z \neq 0; H_z = 0$$

# Transverse Electromagnetic Wave

- both the field components i.e., electric and magnetic fields are totally transverse to the direction of wave propagation.
- It is abbreviated as TEM mode.
- All electromagnetic waves consist of electric and magnetic fields propagating in the same direction of travel, but perpendicular to each other.
- Along the length of a normal transmission line, both electric and magnetic fields are perpendicular (transverse) to the direction of wave travel.

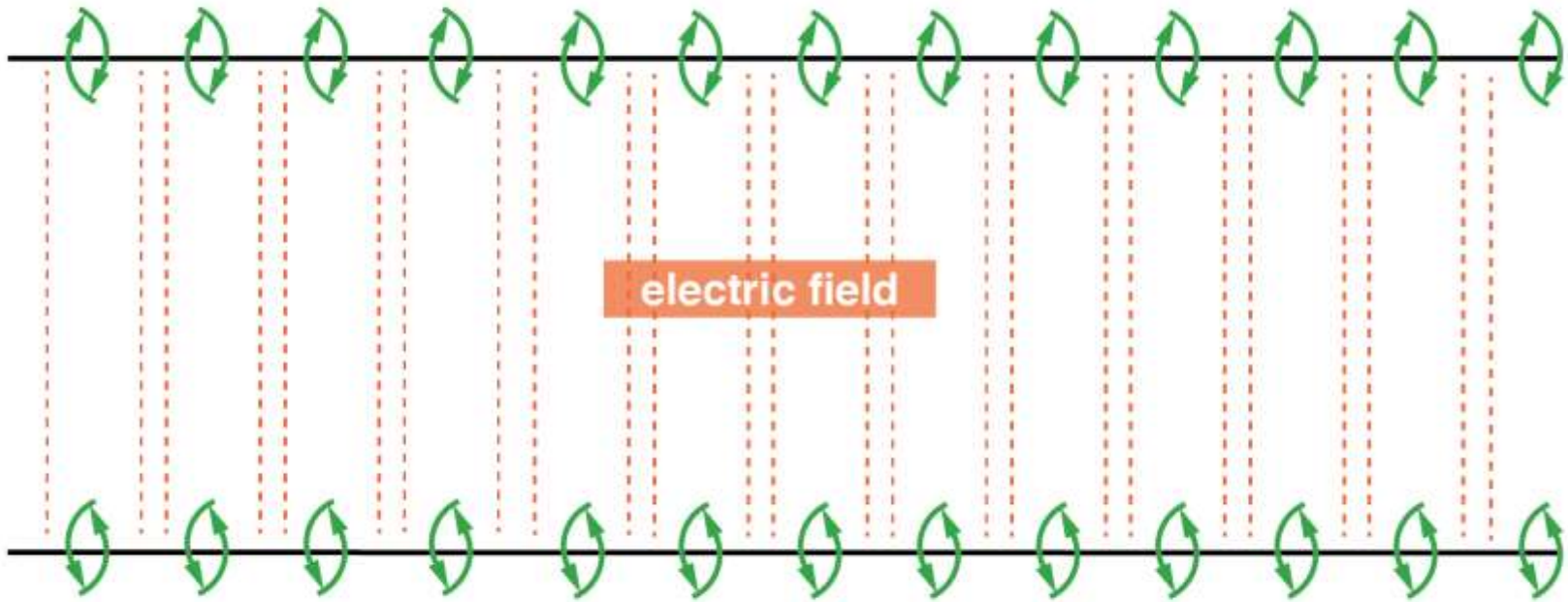
$$E_z = H_z = 0$$

TEM mode



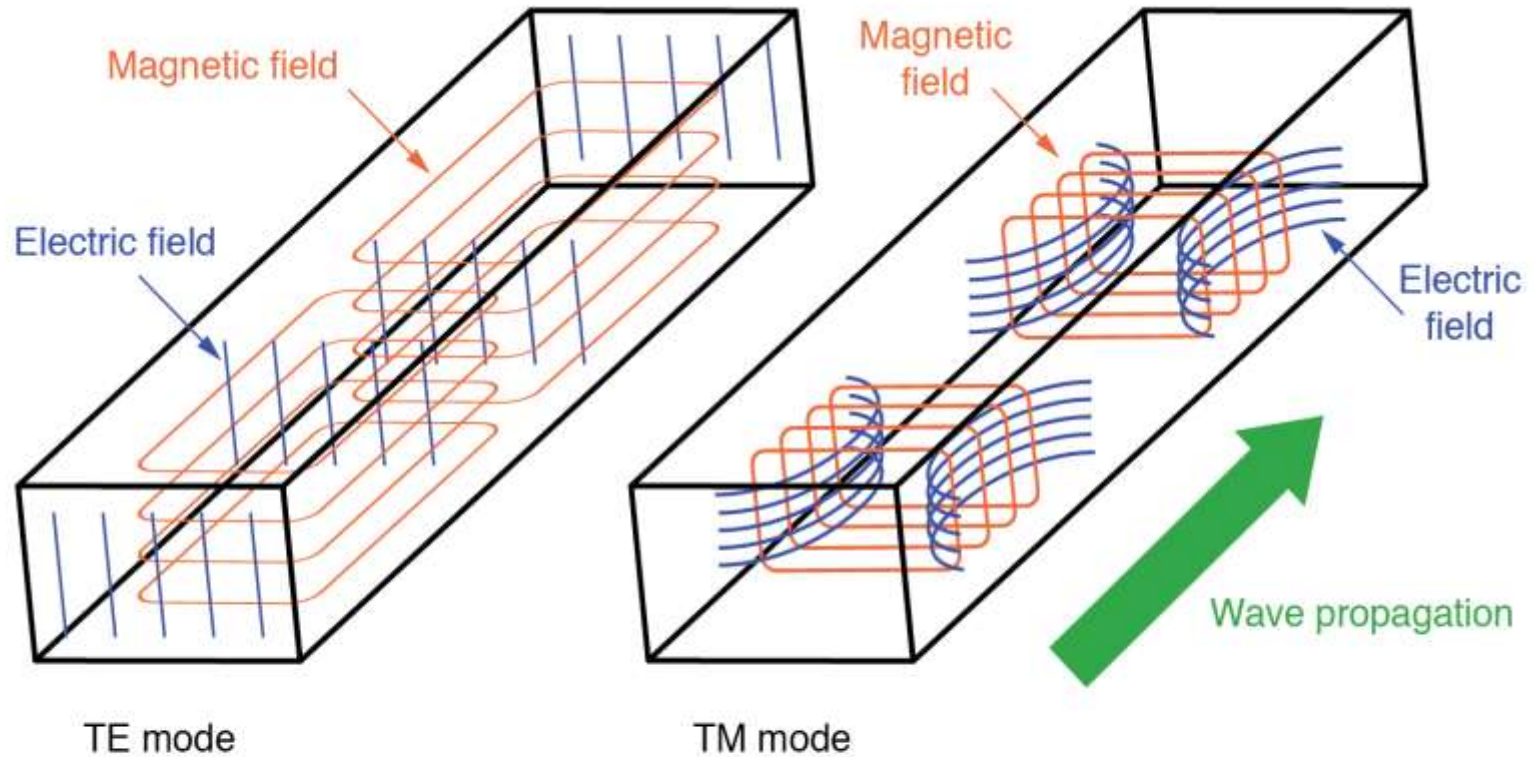
Wave propagation

magnetic field



magnetic field

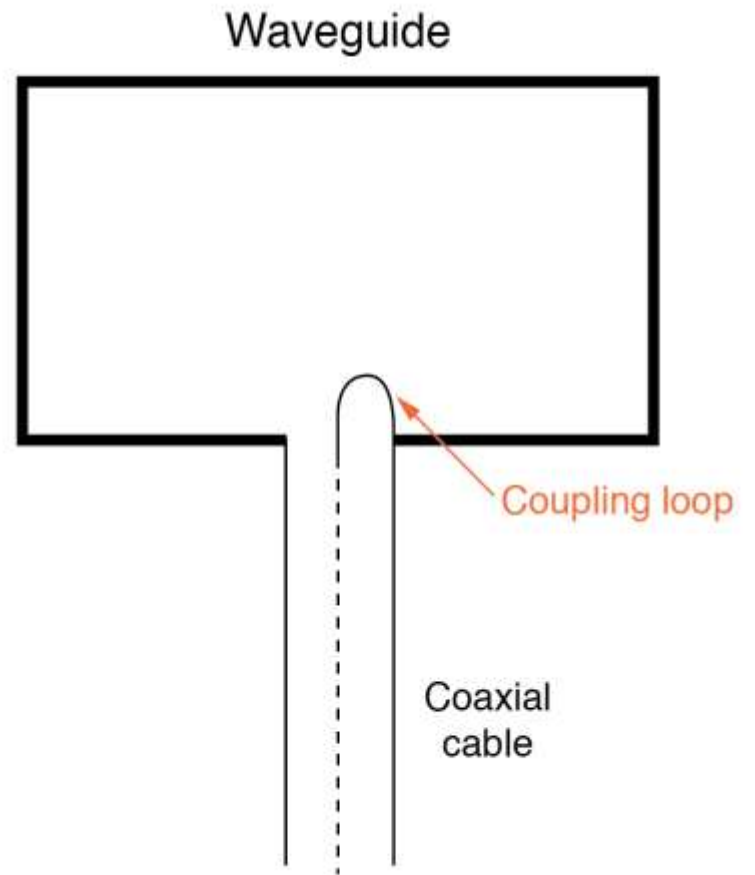
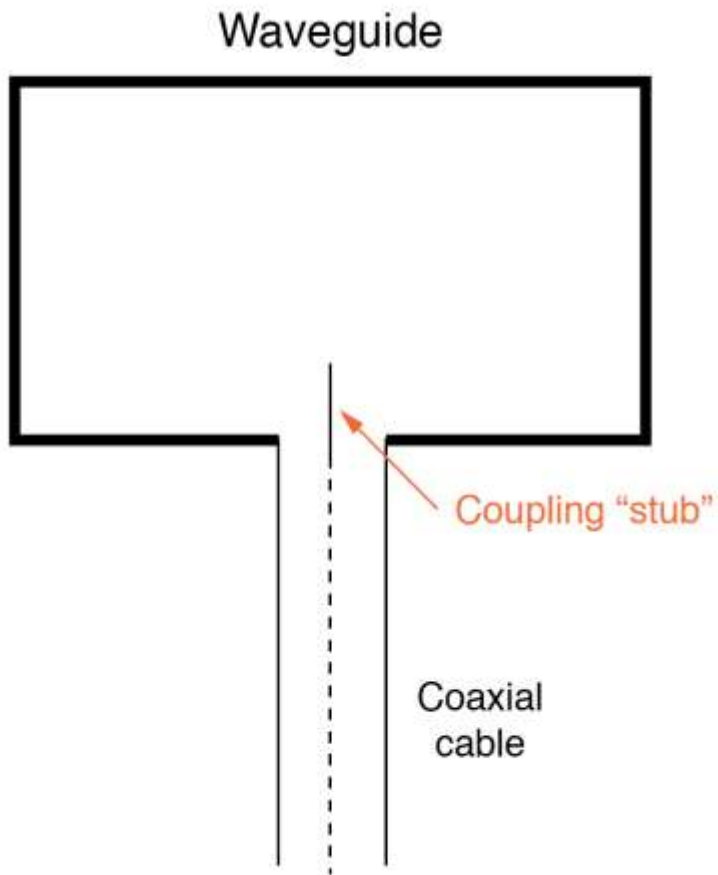
*Both field planes perpendicular (transverse) to direction of signal propagation.*



*Magnetic flux lines appear as continuous loops*  
*Electric flux lines appear with beginning and end points*

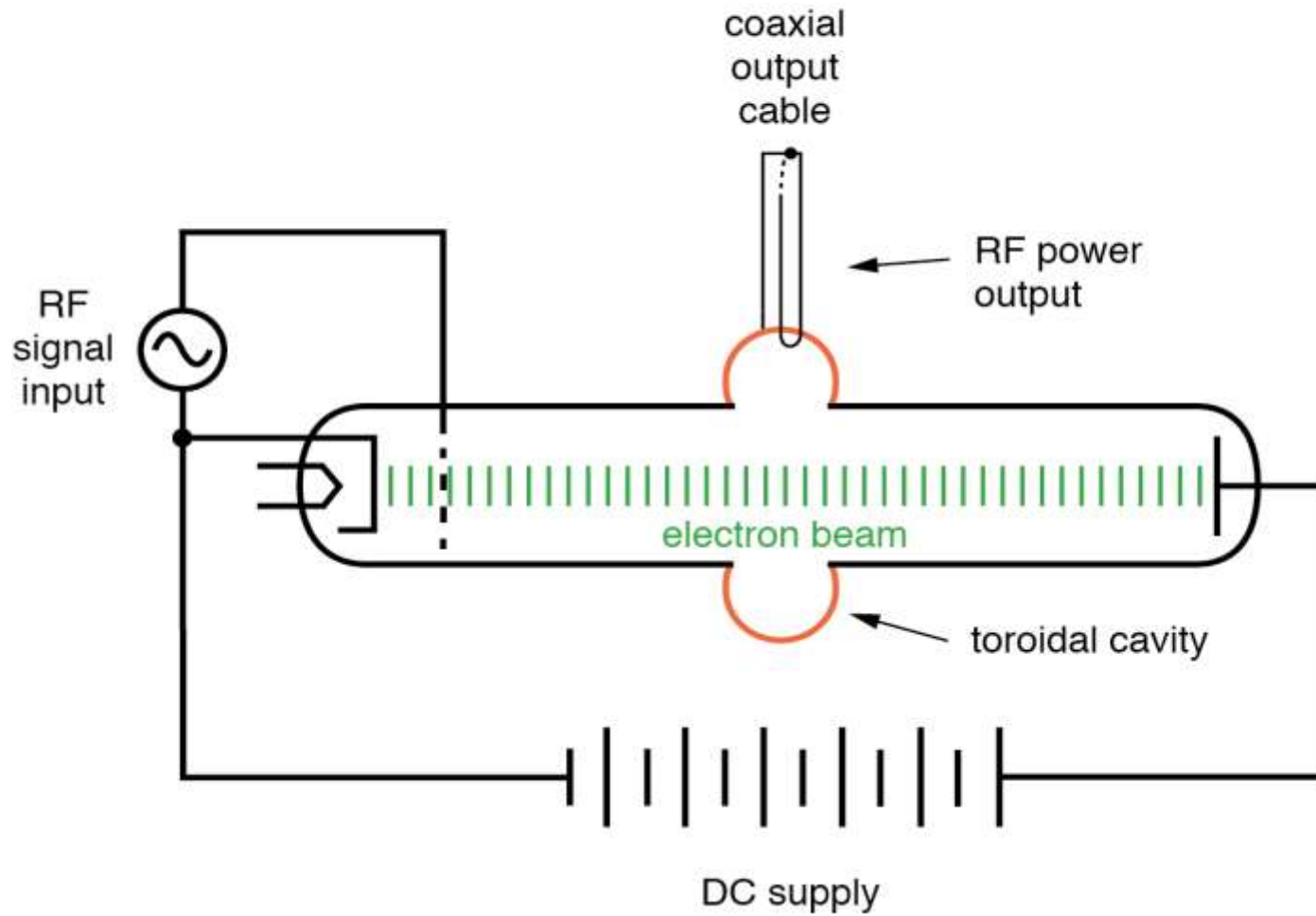
# How Are Signals Introduced to and Extracted from Waveguides?

- Signals are typically introduced to and extracted from waveguides by means of small antenna-like coupling devices inserted into the waveguide.
- Sometimes these coupling elements take the form of a dipole, which is nothing more than two open-ended stub wires of appropriate length.



- In some cases, such as a class of vacuum tube devices called inductive output tubes (the so-called **Klystron Tube** falls into this category), a “**cavity**” formed of conductive material may intercept electromagnetic energy from a modulated beam of electrons, having no contact with the beam itself.

## The inductive output tube (IOT)



# Parameters of a Waveguide

- **Cut-off wavelength:** It is the maximum signal wavelength of the transmitted signal that can be propagated within the waveguide without any attenuation. This means up to cut-off wavelength, a microwave signal can be easily transmitted through the waveguide. It is denoted by  $\lambda_c$ .
- **Group velocity:** Group velocity is the velocity with which a wave propagates inside the waveguide. If the transmitted carrier is modulated, then the velocity of the modulation envelope is somewhat less as compared to the carrier signal.
- This velocity of the envelope is termed as group velocity. It is represented by  $V_g$ .

- **Phase velocity:** It is the velocity with which the transmitted wave changes its phase during propagation. Or we can say it is basically the velocity of a particular phase of the propagating wave. It is denoted by  **$V_p$** .
- **Wave Impedance:** It is also known as the characteristic impedance. It is defined as the ratio of the transverse electric field to that of the transverse magnetic field during wave propagation at any point inside the waveguide. It is denoted by  **$Z_g$** .

- **Advantages of waveguides:**
  - In waveguides, the power loss during propagation is almost negligible.
  - Waveguides have the ability to manage large-signal power.
  - As waveguides possess a simple structure thus their installation is somewhat easy.
- **Disadvantages of waveguides:**
  - Its installation and manufacturing cost is high.
  - Waveguides are generally rigid in nature and hence sometimes causes difficulty in applications where tube flexibility is required.
  - It is somewhat large in size and bulkier as compared to other transmission lines.

# WAVEGUIDE COMPONENTS

- Waveguide carries the power from the transmitter end to the input of an antenna.
- However, the **entire waveguide system cannot be formed into one piece.**
- constructed using many individual sections or components, and these sections have to be connected with waveguide bends, joints, and so on.

- a variety of signal control components such as directional couplers, circulators, isolators, attenuators, phase shifters, and multiport junctions have to be used in the microwave system.
- For example, waveguide attenuators and phase shifters are **used to control the amplitude and to shift the phase,** respectively.

- The isolators and circulators **allow the microwave signals to travel in only one direction.**
- whereas the directional couplers sample the power flowing in one direction and are used for determining the frequency and the level of power.
- The waveguide components are characterized by the network parameters known as ***scattering parameters.***

# COUPLING MECHANISMS

- The microwave signal to be carried from one point to other is introduced into the waveguide with an antenna like **probes or loops**.
- The probe is coupled to the waveguide **parallel to the point where the electric field is maximum** and the loops are **coupled at a point where the magnetic field strength is maximum**.

# Probes

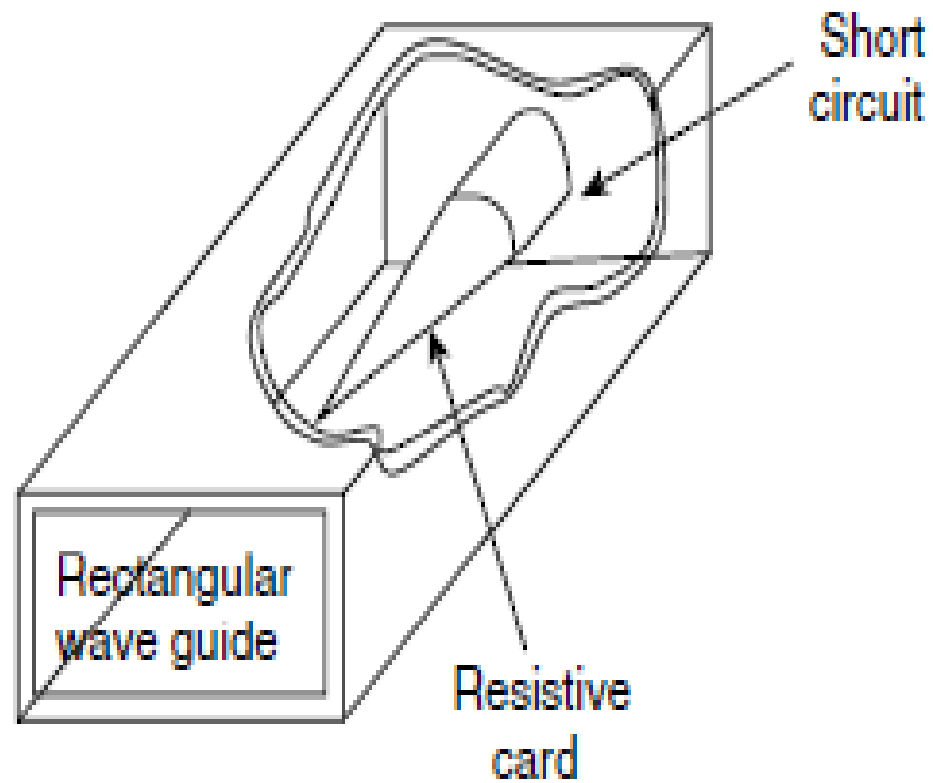
- The probe is defined as a  $\lambda/4$  vertical antenna that is inserted in the waveguide at a distance of  $\lambda/4$  from the closed end and the center of the broader dimension of the waveguide.
- that particular point, because there the electric field is maximum.
- The probe will now act as an antenna that is polarized in the plane parallel to that of an electric field.

# WAVEGUIDE DISCONTINUITIES

- **Any interruption** in the uniformity of a transmission line leads to **impedance mismatch** and is known as **impedance discontinuity** or **discontinuity**.
- In a waveguide system, when there is a mismatch, **reflections will occur**.
- In **transmission lines**, in order to **overcome this mismatch**, **lumped impedances** or **stubs** of required values are placed at the pre-calculated points.
- In waveguides also, some discontinuities are used for matching purposes.

# Matched Loads

- The **most commonly used waveguide terminations** are the matched loads.
- Whenever the load impedance and characteristic impedance of the **transmission line are not matched** /equal, **reflections exist**.
- These reflections would cause **frequency instability to the source**.
- Matched loads are **used for minimizing the reflections by placing a material in the waveguide parallel to the electric field to absorb the incident power completely**.
- **One of the methods** involved in the matched load is to **place a resistive card in the waveguide parallel to the electric field** as shown in Fig.6.8.



**Figure 6.8** *Matched load with resistive card*

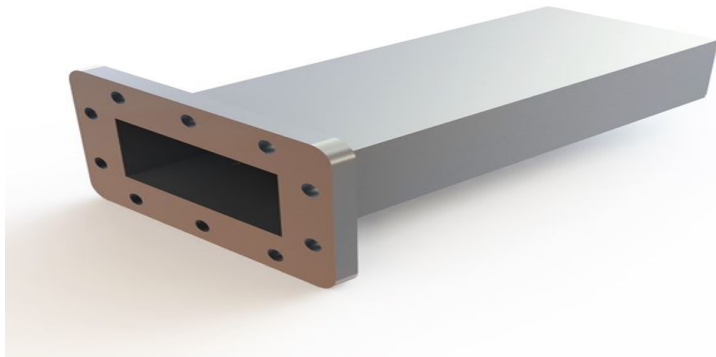
# Termination

- A termination (or load) is a device placed at the end of a microwave transmission line or waveguide to absorb incident RF energy completely, preventing reflections.
- **Purpose:**
  - Provides matched load (usually 50  $\Omega$  or 75  $\Omega$ )
  - Prevents standing waves
  - Ensures accurate measurement of microwave power
  - Protects sources from reflected energy (which can damage TWTs, klystrons, solid-state sources)

# Types OF TERMINATION

- **Fixed / Matched termination:** Provides a constant, non-reflective load.
- **High-power termination:** Uses heat sinks/water cooling.
- **Waveguide terminations:** Usually tapered resistive cards or lossy ceramics inserted inside tuned housings.

- Return Loss (RL) or VSWR
- Ideal termination:  $RL > 30$  dB,
- $VSWR \approx 1.01-1.05$ .



TERMINATION

# Variable Short Circuit

- A **variable short circuit** is a tunable device that presents a **movable short-circuit plane** to a transmission line or waveguide.
- It allows the user to **slide a metal short plate** along the waveguide/coaxial line, changing the position of the short relative to the measurement reference plane.

# Purpose

- Used in **microwave impedance tuning**
- Vital in **slotted-line measurements**
- Employed to adjust:
  - Reflection-coefficient magnitude and phase
  - Smith chart positions
  - Standing wave patterns



# Operating Principle

- A metal plate (shorting plunger) blocks the waveguide → creates a short.
- The plate can move longitudinally.
- Moving the plate changes the electrical length between short and measurement point.
- This produces a controlled phase shift in the reflected wave.
- The resulting impedance at the reference plane becomes:

$$Z_{in} = -jZ_0 \cot(\beta l)$$

Where

$Z_0$ : characteristic impedance  
 $\beta$ : phase constant  
 $l$ : distance from short

# Difference between Termination and Variable Short

Feature	Termination	Variable Short Circuit
Reflection	Ideally no reflection	Full reflection ( $\Gamma = -1$ )
Purpose	Absorb energy	Adjust impedance / create standing waves
VSWR	$\sim 1$	$\infty$
Mechanical Motion	None	Sliding plunger
Used in	Power measurements, VNA calibration loads	Slotted lines, impedance tuners, teaching labs

- Termination to absorb waves after measurement
- Variable short to create controlled standing-wave patterns for measuring:
  - $\lambda_g$  (guide wavelength)
  - VSWR
  - Unknown load impedance

# WG COMPONENTS

- the entire waveguide system cannot be formed into one piece.
- Therefore, it should be constructed using many individual sections or components, and these sections have to be connected with waveguide bends, joints, and so on.
- In addition to this, a variety of signal control components such as directional couplers, circulators, isolators, attenuators, phase shifters, and multipoint junctions have to be used in the microwave system.

# WAVEGUIDE ATTENUATORS

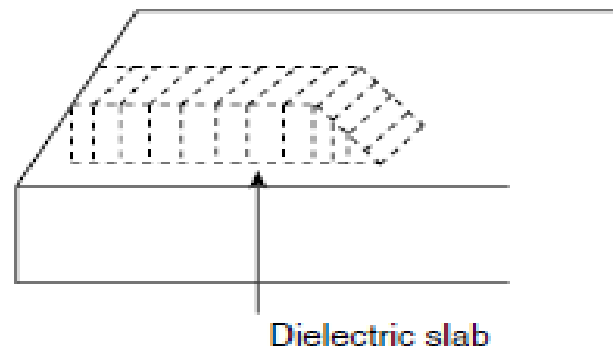
- An attenuator is a passive device that is used to reduce the strength or amplitude of a signal.
- At microwave frequencies, the attenuators were not only meant to do this, but also meant to maintain the characteristic impedance ( $Z_0$ ) of the system.
- If the  $Z_0$  of the transmission line is not maintained, the attenuator would be seen as impedance discontinuity, which causes reflections.

- Usually, a **microwave attenuator controls the flow of microwave power by absorbing it.**
- Attenuation in dB of a device is ten times the logarithmic ratio of power flowing into the device ( $P_i$ ) to the power flowing out of the device ( $P_o$ ) when both the input and output circuits are matched.

$$\text{–Attenuation in dB} = 10 \log P_i / P_o$$

# Attenuators Types

- Fixed
- Mechanically or electronically variable
- Series of fixed steps



**Figure 6.9** *Fixed attenuator*

# Fixed Attenuators

- are used where a fixed amount of attenuation is needed. They **also called *pads***.
- In this type of attenuator **tapering** is provided by placing a short section of a waveguide with an attached tapered plug of absorbing material at the end.
- The **purpose of tapering** is for the gradual transition of microwave power from the waveguide medium to the absorbing medium.
- **Because of the absorbing medium, reflections** at the media interface will be **minimized**.

- In a fixed attenuator (Fig.6.9), plug is nothing but a dielectric slab which has a glass slab with aquadog or a carbon film coating.
- The pad is placed in such a way that the plane is parallel to the electric field. For this, two thin metal rods are used.
- The amount of attenuation provided by the fixed attenuator depends on the strength of the dielectric material, the location and area of the pad, type of material used for pad within waveguide and the frequency of operation.

# Variable Attenuators

- For providing continuous or stepwise attenuation variable attenuators are used.
- The provided attenuation depends on the insertion depth of the absorbing plate into the waveguide.
- The maximum attenuation will be achieved when the pad extends totally into the waveguide.
- This type of variable attenuation is provided by knob and gear assembly which can be properly calibrated.

# WAVEGUIDE PHASE SHIFTERS

- A phase shifter is a **two-port component** that **provides a *fixed* or *variable* change in the phase of the traveling wave.**
- An ideal phase shifter is **lossless and matched.**
- It only **shifts the phase of the output wave.**
- **Electrically controlled phase shifters are much faster than mechanical phase shifters.** They are often based on **p-i-n diodes** or **Field Effect Transistors (FETs).**

# Fixed Phase Shifters

- Fixed phase shifters are usually **extra transmission-line sections** of a certain length that are meant to shift the phase with regard to the reference line.
- Therefore, depending on the bias current, the wave traveling along the transmission line will have an additional traveling path.
- Since these devices are binary switches, only discrete phase shifts are possible.

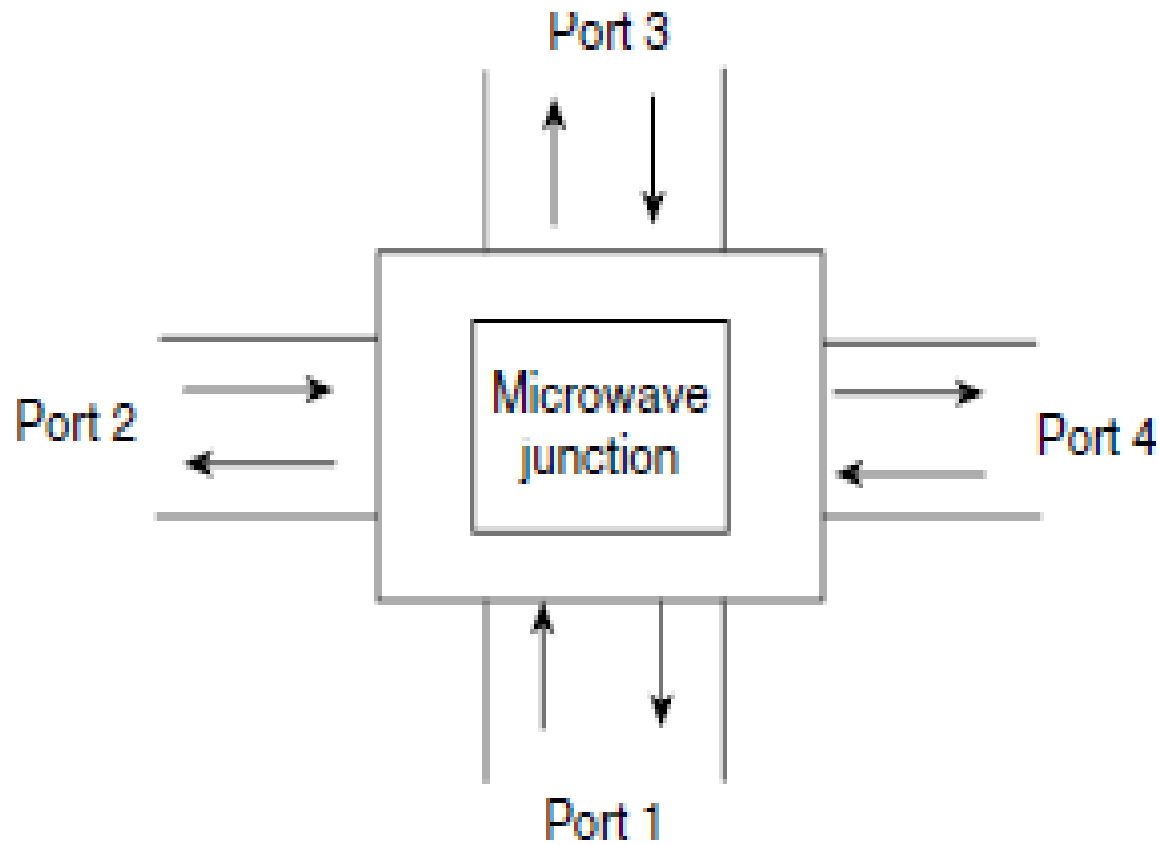
# Variable Phase Shifters

- The variable phase shifters use **mechanical** or **electronic** means to **achieve a dynamic range of phase difference**.
- The **mechanically tuned phase shifter** usually **consists of variable short circuits that are used with hybrids** or, in the case of **waveguide components**, a **dielectric slab with a variable position in the guide**.

# WAVEGUIDE MULTIPOINT JUNCTIONS

- Microwave multipoint junctions are the devices that are **used to split or combine microwave power.**
- The **important parts** of microwave junctions are **ports, arms, and junction regions.**
- **Ports are openings to which the source or load is connected.**
- **Arms are pieces of the transmission lines or waveguides with which the junction device is fabricated.**
- The **junction region** is the **common space** where **all the arms of the device meet each other.**

- microwave junction is an **interconnection of two or more microwave components.**
- Low-frequency circuits can be described by Z, Y, h, and ABCD parameters, and these parameters are related in terms of currents and voltages.
- However, at microwave frequencies, instead of currents and voltages, we talk of traveling waves with their **Associated Powers.**



**Figure 6.13** *Microwave or waveguide junctions*

# Microwave TEE Junctions

- Waveguide Tees are **used for the purpose of connecting a branch or a section of a waveguide in a series or parallel to the main waveguide.**
- The intersection of waveguides in the shape of the English capital letter “T” is called a **T junction.**
- Examples of three-port waveguide T junctions: **E-plane Tee and H-plane Tee.**

## ***E-plane Tees***

- E-plane Tee is a **voltage** or **series junction**. A side arm is attached to a waveguide by cutting a rectangular slot along the broader dimension of waveguide as shown in Fig.6.14 (a).
- If the E-plane junction is **completely symmetrical** and if **waves enter through the side arm**, the waves that **leave the main arms are equal in magnitude and opposite in phase**.
- Since the **electric field lines change their direction** when they **come out of ports 1 and 2**, it is called an ***E-plane Tee***.

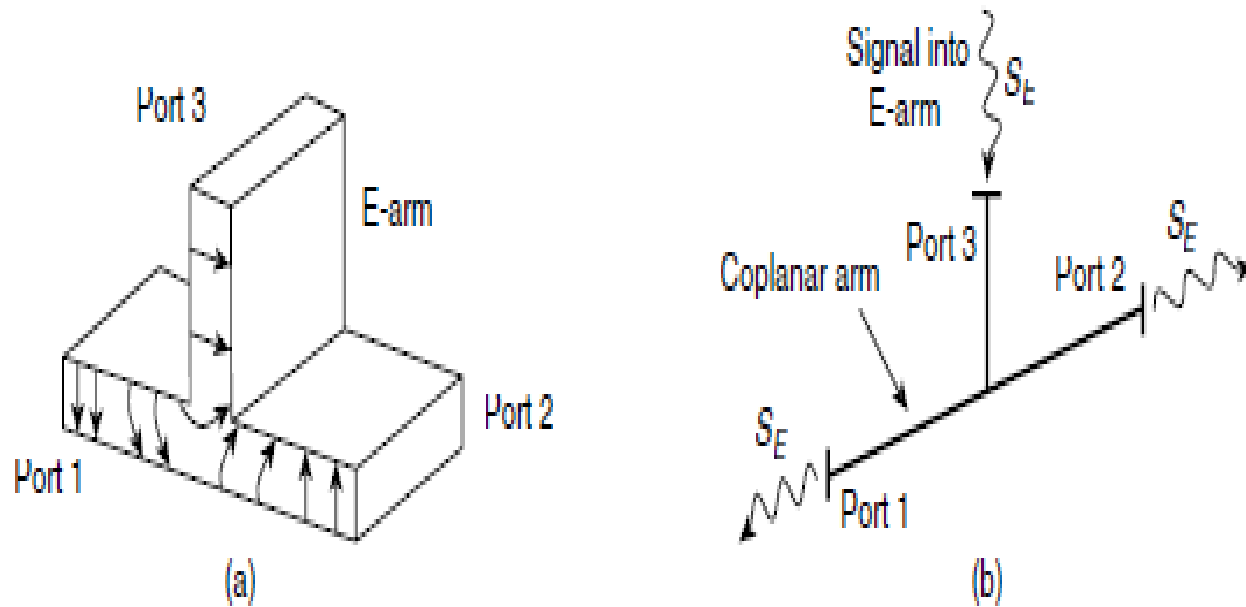


Figure 6.14 (a) *E-plane waveguide Tee junction*; (b) *Transmission-line equivalent circuit of E-plane Tee*

# As power divider

- If the amplitude of the input wave at port 3 is  $A$ , the amplitudes of the waves at ports 1 and 2 are same and equal to  $A/\sqrt{2}$ . They are out of phase when its collinear arms lengths are same.
- When the power incident at port 3 is  $P$ , the powers that appear at ports 1 and 2 are  $P/2$  each.
- *i.e.*,  $P_3 = P$ ,  $P_2 = P/2$ ,  $P_1 = P/2$ ,  $P_3 = P_1 + P_2 = 2P_1 = 2P_2$
- The amount of power coming out of ports 1 and 2 in decibels is
- $-10 \log (P_1 / P_3) = -10 \log (P_1 / 2P_1) = -10 \log (P_2 / 2P_2) = -10 \log (1/2) = 3dB$
- That is why it is called a **3dB splitter**.
- **As power combiner**

## *H-plane Tee*

- H-plane Tee is a **current, shunt, or parallel junction**. Since the **axis of the side arm is parallel to the plane of the H field of the main waveguide**, it is called *H-plane Tee*.
- A rectangular slot is cut along the narrow dimension of a long waveguide, and a side arm is attached as shown in Fig.6.15 (a).
- If the H-plane junction is **completely symmetrical** and **waves enter through the side arm**, the **waves that leave the main arms are equal in magnitude and phase**.

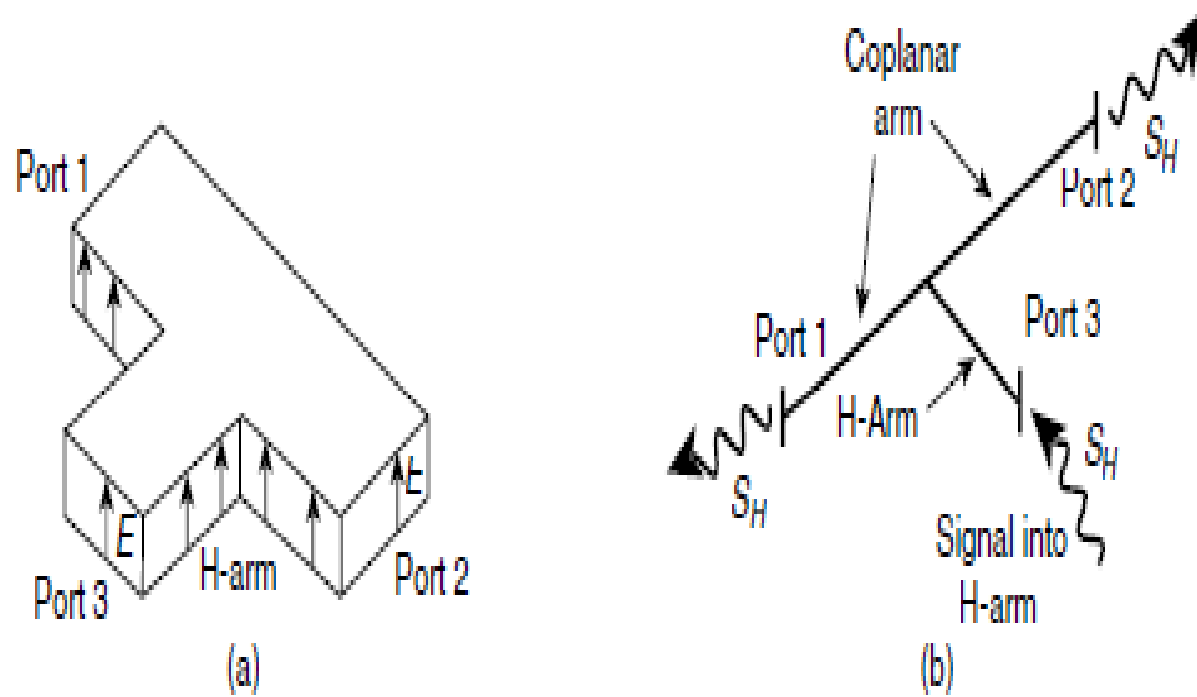


Figure 6.15 (a) *H-plane Tee junction*; (b) *Transmission-line Equivalent circuit of H-plane Tee*

## As Power Divider

- They are inphase when its collinear arm lengths are same. If the amplitude of the input wave at port 3 is  $A$ , the amplitudes of the waves at ports 1 and 2 are same and equal to  $A/\sqrt{2}$ .
- It is called a *3dB splitter*, because when the power incident at port 3 is  $P$ , the powers that appear at ports 1 and 2 are  $P/2$  each.

# **Comparison of E-plane Tee with H-plane Tee**

<b>E-plane Tee</b>	<b>H-plane Tee</b>
In an E-plane Tee, the axis of its side arm is parallel to the electric field of the main waveguide.	In an H-plane Tee, the axis of its side arm is parallel to the magnetic field or shunting the electric field of the main waveguide.
The E-plane Tee is also called a <i>series Tee</i> .	An H-plane Tee is also called a <i>parallel</i> or <i>shunt Tee</i> .
When the power is fed at port (3), that is, at the side arm, the resulting power is equally divided between port (1) and (2), but a phase shift of 180° is introduced between the two outputs.	When the power is fed at port (3), that is, at the side arm, the resulting power is equally divided between port (1) and port (2) within phase.
When the equal input power is fed to both ports (1) and (2), no output is obtained at port (3).	When the equal input power is fed to both ports (1) and (2), the maximum power (i.e., addition of two inputs) is obtained at port (3).
When the input signal is applied at any one of the collinear ports i.e., port (1) or port (2), the resulting power is obtained at port (3).	When the input is applied at any one of the collinear ports i.e., port (1) or port (2), the resulting power is obtained at port (3).

# ***Magic Tee***

- The **combination of an E-plane Tee** and an **H-plane Tee** is called as Magic Tee.
- A Magic Tee can be formed by attaching arms to the slots made in the broad and narrow walls of a waveguide.
- It is also called as **hybrid Tee** in which the **power distributes equally between the output ports**.
- The **outputs** may have **0°** or **180°** phase **difference**. Magic Tee is a **3db hybrid coupler** which is also called as an **anti-symmetric coupler**.

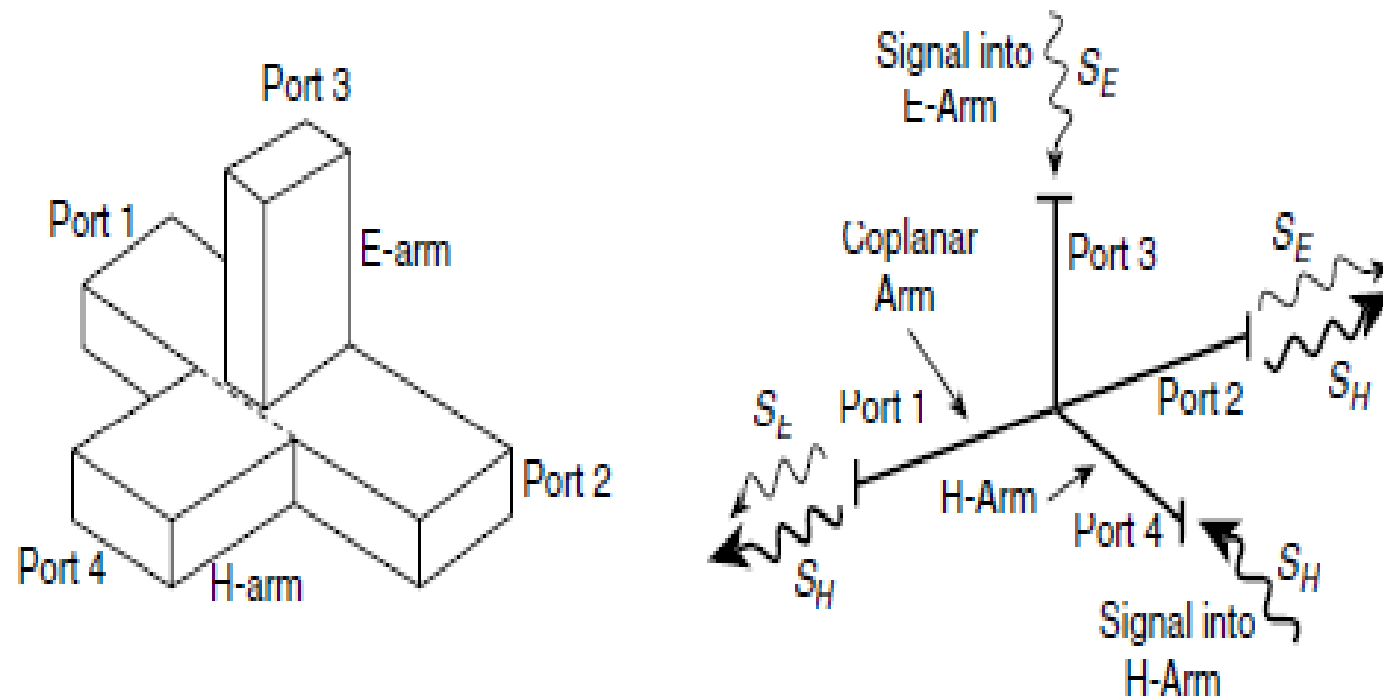


Figure 6.16 (a) Hybrid (Magic) Tee junction and its equivalent circuit

# DIRECTIONAL COUPLERS

- In some applications such as radar, very often we need to check the exact frequency/power applied to the antenna or that is radiated into space.
- Directional couplers **allow us** to sample or **monitor** the frequency level and/or **power level of a given signal as it goes from one point to another.**
- The directional coupler is a **4–port reciprocal device.** Direction couplers **consist of two transmission lines** and a mechanism for **coupling signals** between them.
- Let us **understand** the meaning of the two terms (viz. **coupler** and **directional**) in the directional coupler.

# Coupler

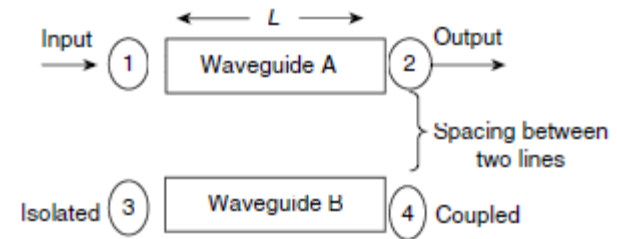


Figure 6.19 (a) Coupler

- A coupler is a device that **consists of two waveguides** which are placed very close to each other (as shown in Fig. 6.19 (a)).
- Thus, a portion of energy traveling in waveguide A will be coupled on waveguide B.
- We can make this coupler directional by using a specific length ( $L$ ) of the transmission line.

# Directional

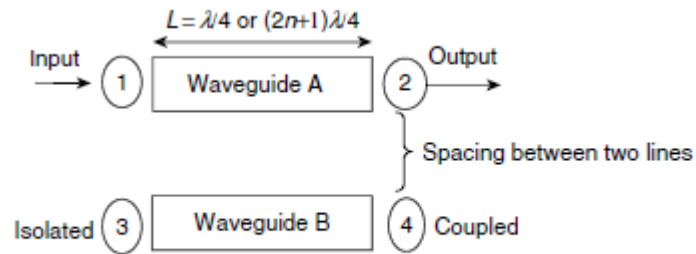


Figure 6.19 (b) Coupler with a specific length of  $\lambda/4$

- The term *directional* means the **energy is passed in one direction only** and **no energy passes in the reverse direction**.
- The directional property is obtained by using a specific length ( $L$ ) of a transmission line, that is, a **quarter wavelength ( $\lambda/4$ )**.
- A  $\lambda/4$  transmission line offers **high impedance at one end** and **low impedance at the other end**.
- Therefore, the **specific length ( $L = \lambda/4$  or  $(2n+1)\lambda/4$ )** makes a coupler directional over a certain band of frequency (as shown in Fig.6.19 (b)).

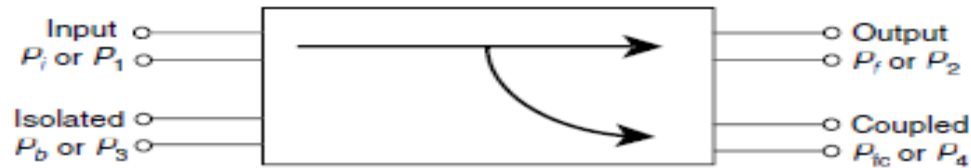


Figure 6.19 (c) *Four-port directional coupler*



Figure 6.19 (d) *Schematic of directional coupler*

- $P_i$  or  $P_1$  = power incident at port 1
- $P_f$  or  $P_2$  = forward power or output power at port 2
- $P_b$  or  $P_3$  = reflected power at isolated port 3 in secondary waveguide
- $P_{fc}$  or  $P_4$  = forward coupled power in the secondary waveguide, that is, at p-4

# Parameters that Characterize the Directional Coupler

- A directional coupler is characterized by 3 parameters:
  - **Coupling factor**
  - **Directivity**
  - **Isolation**

- **Coupling factor (C):** It indicates the fraction of input power coupled to the coupled port.

$$C = 10 \log (P_1 / P_4) \text{ dB}$$

- Where
  - $P_1$  is the power incident at port 1, and  $P_4$  is the power coupled at port 4.
- **2. Directivity (D):** Directivity is the ability to isolate coupled (port 4) and backward (port 3) ports.

$$D = 10 \log (P_4 / P_3) \text{ dB}$$

- **3. Isolation (I):** *Isolation* is defined as the ratio of power incident to the power coupled in the isolated port and is expressed in dB.

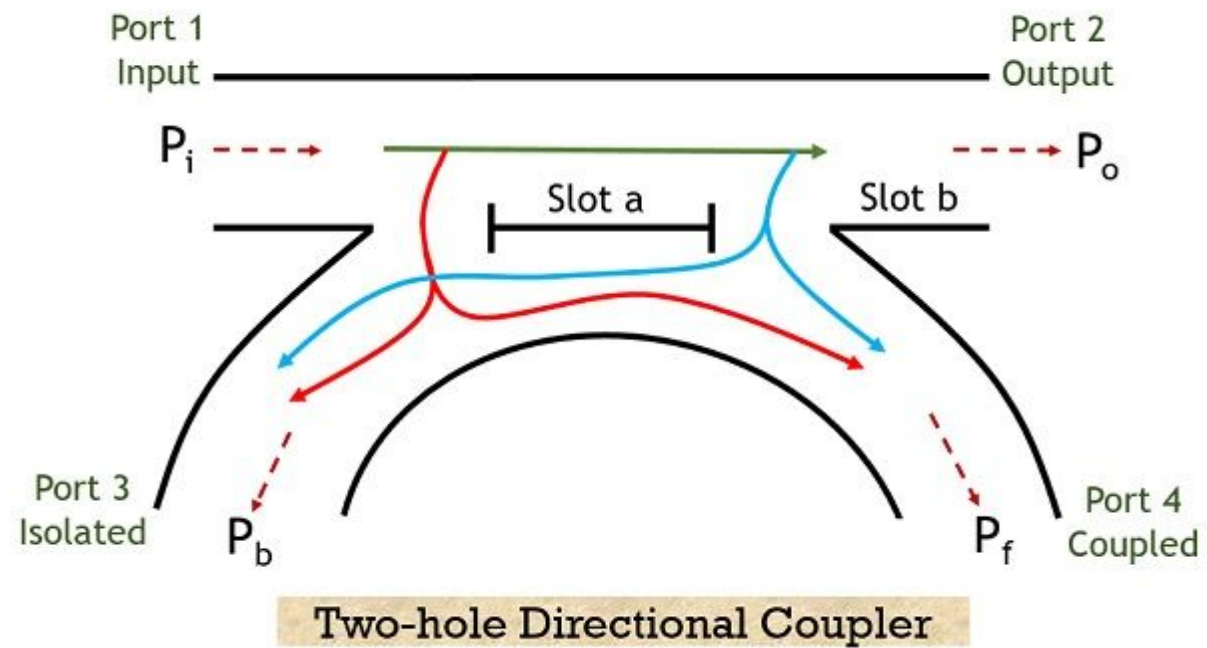
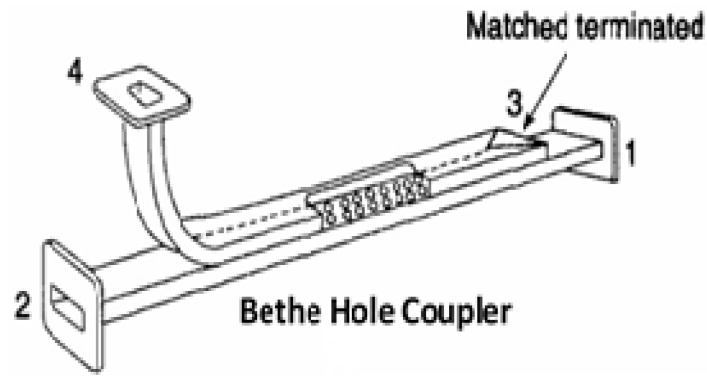
$$I = 10 \log (P_1 / P_3) \text{ dB}$$

- In an ideal directional coupler,  $D$  and  $I$  are infinite (as  $P_3 = 0$ ), and  $C$  is of the order of 10 dB.

- Bethe Hole and Two-Hole Couplers are types of waveguide directional couplers that use apertures to transfer power;
- the Bethe hole uses a single, small hole for narrow-band, reverse coupling (often at an angle).
- while the two-hole design uses two holes spaced ( $\lambda_g/4$ ) apart to achieve better directivity by cancelling back-coupled power in the isolated port, making it a forward coupler ideal for wider bandwidths and power monitoring.

# Bethe Hole Coupler

- Structure: A single small hole in the common wall between two waveguides, often placed at an angle (e.g., 90 degrees) to each other.
- Coupling: Uses a single aperture for coupling, leading to a narrow operating bandwidth.
- Type: A "reverse coupler," meaning it couples power in the backward direction from the main line to the secondary line.
- Simplicity: Considered the simplest form of waveguide directional coupler.



Electronics Desk

# Two-Hole Coupler

- Structure: Two holes in the common wall of two parallel waveguides.
- Spacing: Holes are spaced by a quarter-guide wavelength ( $\lambda_g/4$ ).
- Working: Signals coupled through both holes add constructively at the coupled port (Port 4) but cancel out at the isolated port (Port 3) due to a  $180^\circ$  phase difference, providing high directivity.

- Type: A "forward coupler" designed to sample power in the forward direction.
- Application: Ideal for monitoring power and measuring reflections due to its improved directivity over single-hole types.







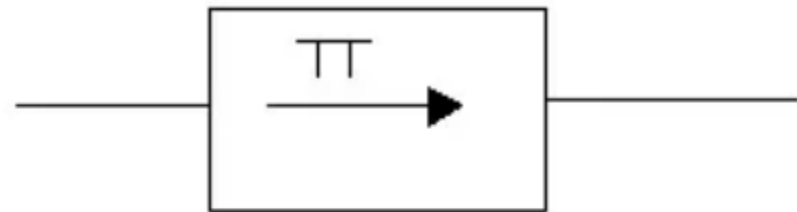
# Microwave Propagation in Ferrites

- **Microwave Gyrotator**
- **Isolator**
- **Circulator**

- **Passive Components** are
- non-powered circuit elements that manage,
- route,
- filter, or
- combine microwave energy without amplification,
- storing or dissipating it, and
- are crucial for building high-frequency systems by controlling signal flow and impedance.
- like waveguides, couplers, filters, attenuators.

# Microwave Gyrator

- a **Two-port Device** that introduces a **180-degree phase** difference for transmission from port 1 to port 2.
- while exhibiting **no phase shift** for transmission in the opposite direction (from port 2 to port 1).



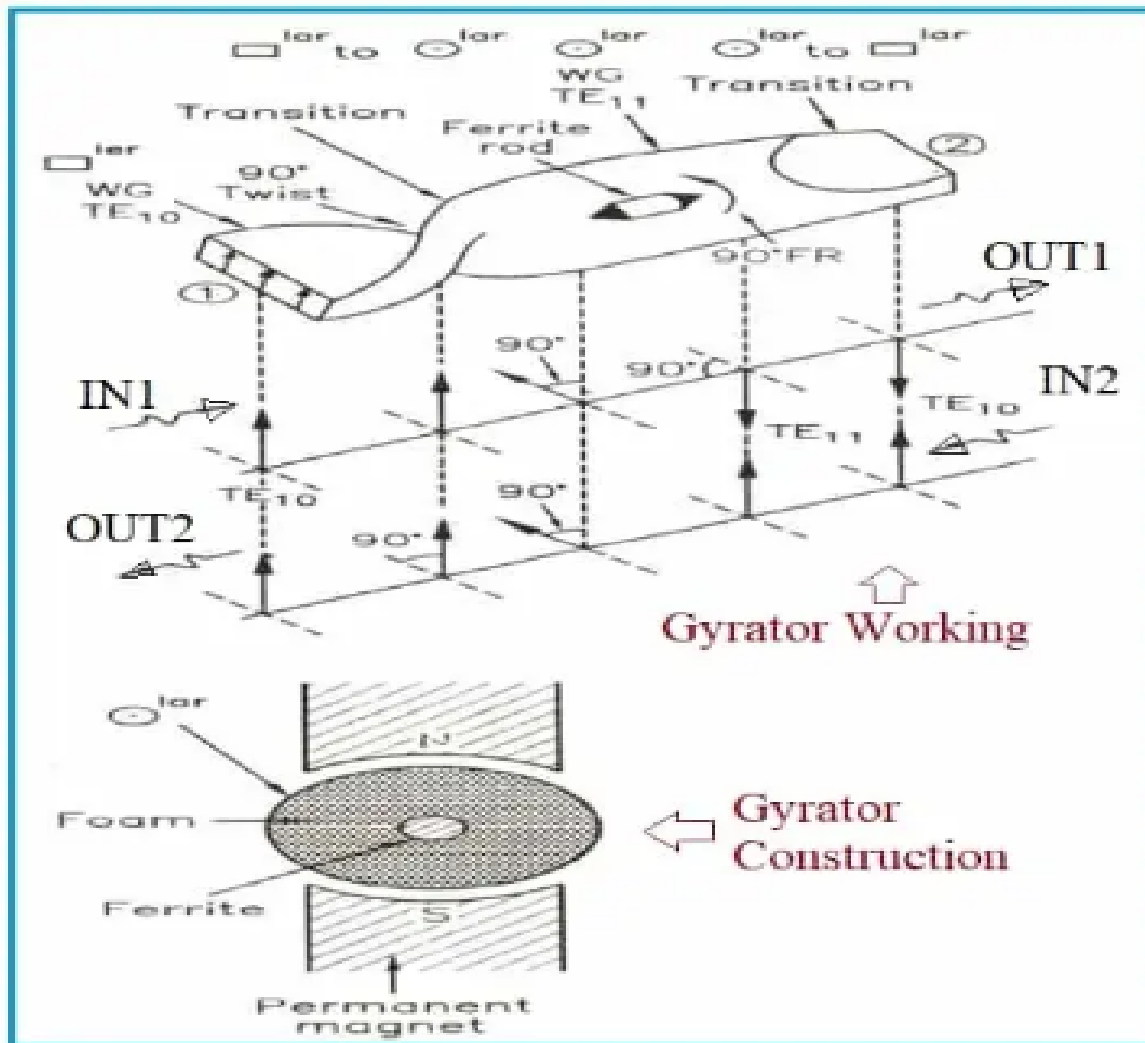
$$S = \begin{bmatrix} 0 & 1 \\ -1 & 0 \end{bmatrix}$$

# Construction

- is a **passive**, two-port electrical network element that exhibits gyration.
- Gyration is the property where the phase relationship between the voltage and current at the ports is rotated in a specific direction.

- gyrator typically **consists of a thin, circular ferrite rod, tapered at both ends.**
- This rod is housed within a circular waveguide, supported by polyfoam.
- A permanent magnet surrounds the waveguide, generating a DC magnetic field essential for the ferrite's proper operation.

- At the input end, a 90-degree twisted rectangular waveguide is installed.
- The tapered ends of the ferrite rod serve to reduce attenuation and facilitate a smooth rotation of the polarized wave.



# Working Principle

- **Case 1: Wave Enters Through Port 1**
- When a wave enters through port 1, its plane of polarization rotates by **90 degrees** due to the twist in the waveguide.
- Subsequently, it undergoes a **Faraday Rotation** of **another 90 degrees** due to the ferrite rod.
- These combined phase shifts result in a total phase shift of 180 degrees as the wave exits through port 2.

- **Case 2: Wave Enters Through Port 2**
- Conversely, when a wave enters through port 2, it experiences a **Faraday rotation of 90 degrees** in the **anti-clockwise direction**.
- This 90-degree shifted wave then passes through the twist, which **rotates it back by 90 degrees in the opposite direction**, effectively **canceling out** the previous phase shift.
- Consequently, the wave arrives at port 1 with a 0-degree phase shift.
- Therefore, an EM wave fed at port 2 does not undergo any phase change as it passes through the gyrator.

# Gyrator S-Matrix

- The S-matrix (scattering matrix) for a gyrator is typically represented as a 2x2 matrix, describing the relationship between the **incident and reflected waves at the ports of the gyrator**.
- Gyrators are often implemented using passive components like resistors, capacitors, and occasionally operational amplifiers.

# Applications of Gytrators

- **Microwave Filters:** Gytrators are frequently used in the design of microwave filters, especially where the physical size of an inductor poses a limitation.
- **Impedance Matching Networks:** They can be employed in impedance matching networks.
- **Frequency Synthesizers:** Gytrators can provide tunable inductance in frequency synthesizers, which are widely used in communication systems to generate stable and precise output frequencies.
- **RF Amplifiers:** Gytrators are used in certain RF amplifier configurations to replace inductors.

# Isolator

- defined as non-reciprocal, passive two ports, ferromagnetic device in which **power is transmitted in one direction and absorbed in the other direction.**
- Isolators are non-reciprocal devices, meaning their behavior in one direction is very different from that in the other direction.

# Construction

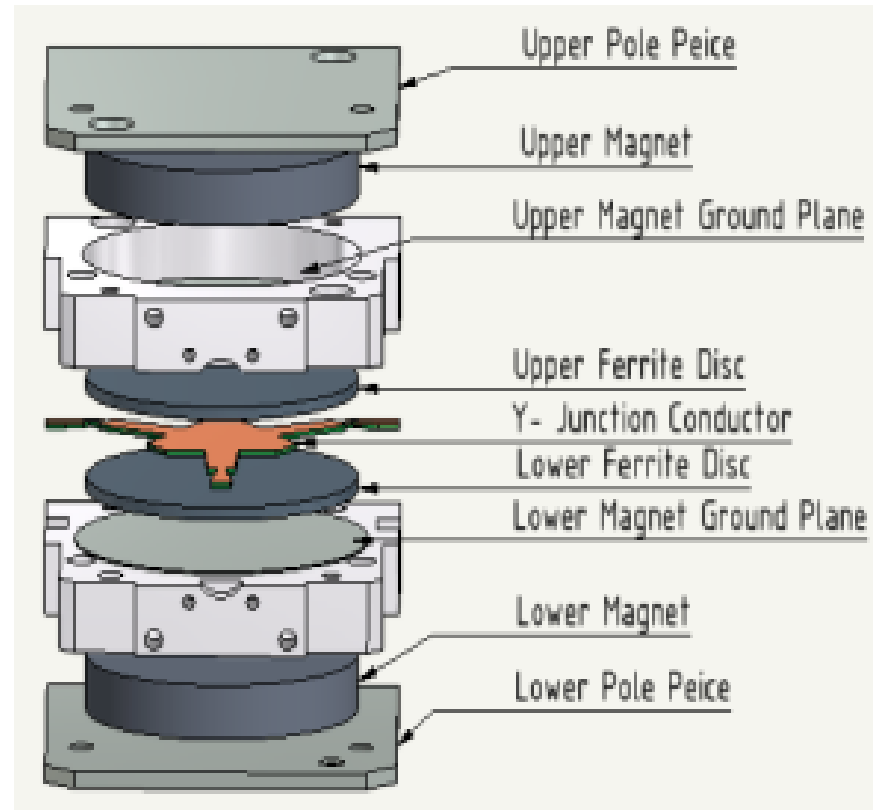
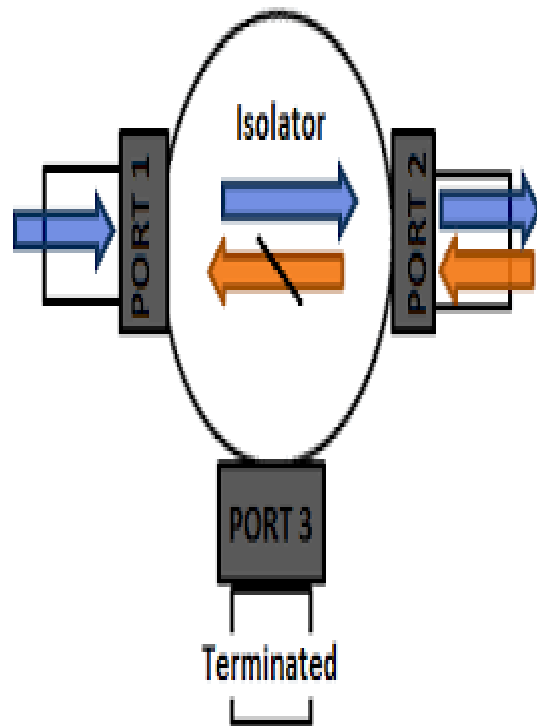
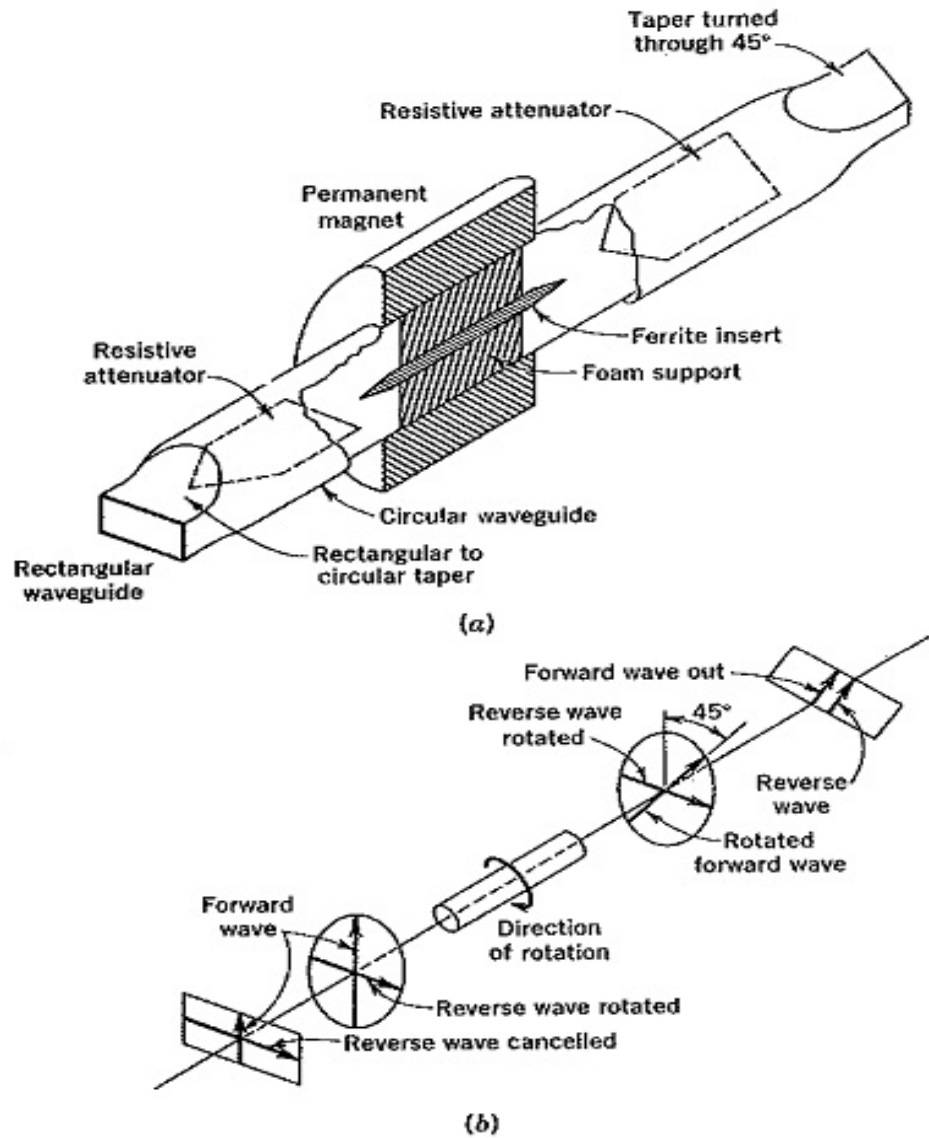


Figure 2: Isolator Construction Elements



**FIGURE 10-40 Faraday rotation isolator. (a) Cutaway view; (b) method of operation.**

- Typical junction Isolator **consists of a Y- junction stripline circuit sandwiched between two ferrite discs**, an upper and lower magnetically biased permanent magnets and ground planes.
- The ferrite materials, magnets are selected according to the frequency of operation, input power ratings and intended application.
- In an Isolator, **the magnetic field is applied through the vertical axis of this assembly, results into a circulation of the RF energy from one port to the other**, depending upon from which port energy is coming from.

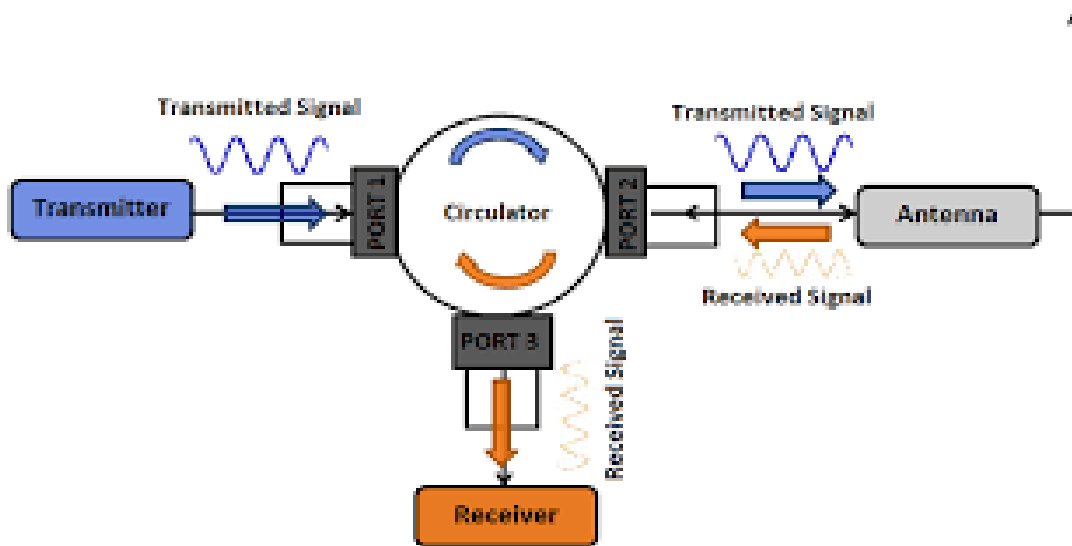
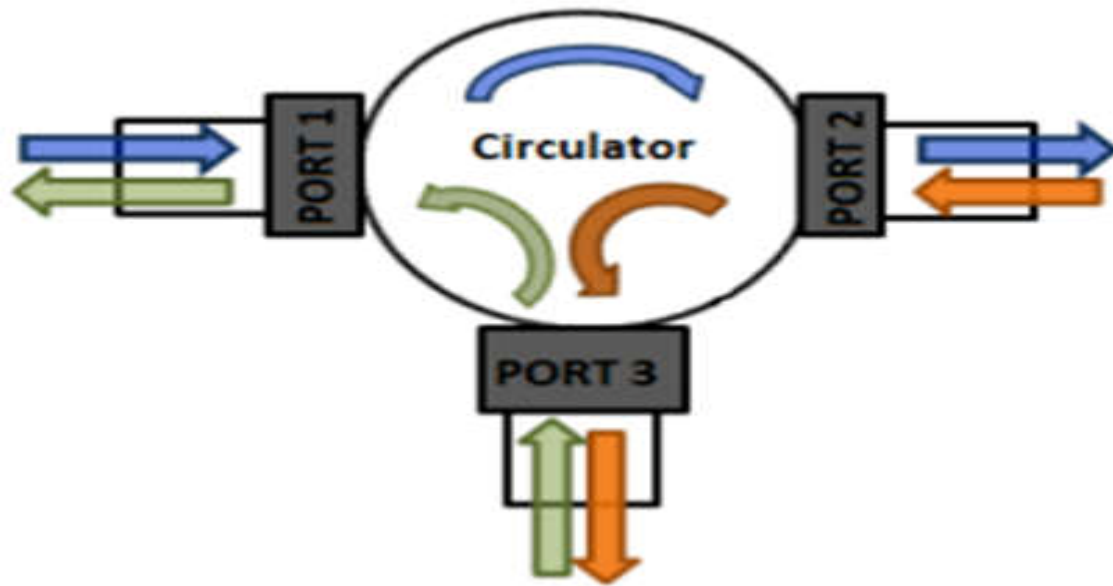
# Working Principle

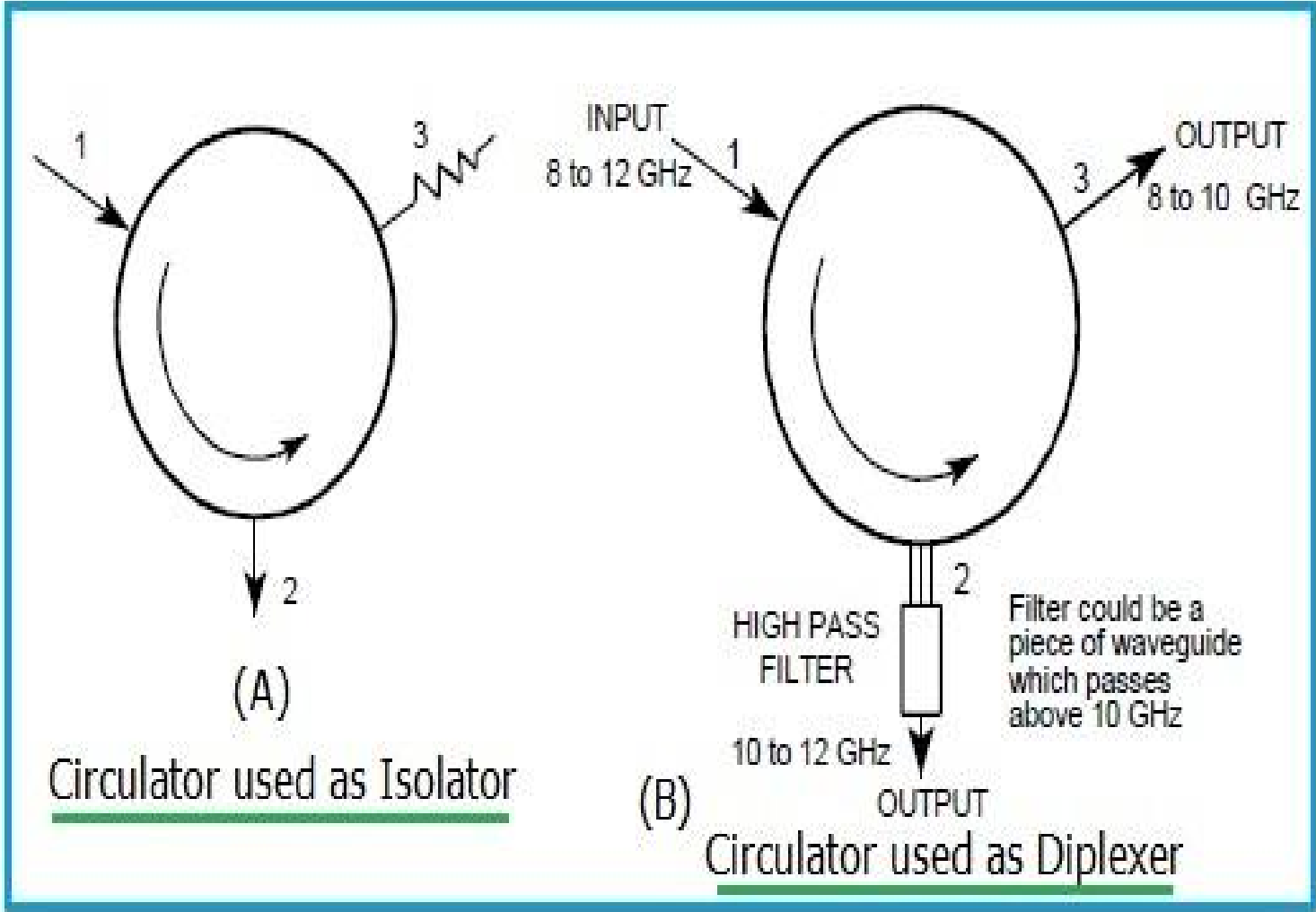
- Due to only two ports, an Isolator has only one path for RF energy to flow where the power is transmitted in one direction and absorbed in the other direction.
- That means RF energy can only enter port 1 and travel to port 2.
- Any RF signal that enters from port 2 will be directed to the matched termination on port 3 and will be dissipated as heat.
- This mechanism heavily attenuates an RF signal entering port 2 before it reaches port 1.

# CIRCULATOR

- as a non-reciprocal, passive three ports, ferromagnetic device in **which power is transferred from one port to the next adjacent port.**
- They typically have three and four ports and they are used in RF system designs that require power from one port to be transferred to another whilst isolating power from the other.
- An RF signal experiences a **low loss in the direction of arrow** and **high loss in reverse direction while propagating** through the Circulator.

- A signal is placed at port 1 and port 2 is well matched, the signal will exit at port 2 with very little loss (**typically 0.4 dB**).
- If there is a mismatch at port 2, then some signal power will be reflected towards port 3.
- The **ports are placed 120°** apart so that they are **equi-spaced around a circle**.
- The arrows within the circulator signify the **direction of the magnetic field** when the signal is applied to one of the ports of these devices.





# Working of Circulator

- To understand how the circulators control the flow of signal--
- let's think a cup of water and place a spoon in it then stir it in the direction of clockwise.
- If we drop a pinch of pepper into the cup and stir continuously, so we can observe that the pepper can easily follow the motion of water because of the motion of water is strong.

- The communication of the Magnetic Field toward the ferrite material within circulator makes magnetic fields related to the flow of water in the cup.
- The rotating field is extremely strong & will cause any RF signals inside the frequency band at one port to track the magnetic flow toward the nearby port but not in the reverse direction.

# Circulator Characteristics

- Insertion loss is  $< 1$  dB
- Isolation range is approximately from 30dB to 40 dB
- VSWR (voltage standing wave ratio) is  $< 1.5$

# Insertion Loss

- The total amount of energy lost while transmitting the RF **signal from one port to another port** of the Circulator is called as Insertion Loss.
- Insertion loss is the ratio of the output signal to the input signal & it is measured in decibels (dB).

$$I.L. = 10 \log_{10} \left[ \frac{P_{out}}{P_{in}} \right] \text{ [dB]}$$

- The insertion loss is **frequency dependent**, it increases with operating frequency.
- Hence, insertion loss of a Circulator becomes more significant at higher frequencies due to more power being dissipated as a heat.

# Isolation

- A **measure of the separation of signal levels on adjacent ports** of a Circulator is called as Isolation.
- The **greater the isolation value**, the **lesser will be the interference from a signal on one port relative to an adjacent port**.
- The isolation of a Circulator is mainly dependent on following two parameters:
  - - Termination match level
  - - VSWR of terminated port

# Applications of Circulators

- Duplexer
- Isolator
- Reflection amplifier
- Radar systems
- Amplifier systems
- Antenna transmitting or receiving

# RF Circulator & Isolator Specifications

- **Frequency:** operate between frequencies of about 750MHz up to 20 GHz or so, although specialized (and expensive) designs can be made to work on bands between **100 MHz and 100 GHz**.
- **Impedance:** **characteristic impedance** needs to be specified. The most popular impedance level for RF circulators is **50Ω**.
- **Insertion loss:** This is the attenuation measured in dB of the incident signal from one port to the next, i.e. in the forward direction. Typical figures might be in the range from **0.1 to 0.75 dB**.

- **Isolation:** the attenuation in the **reverse flow direction measured** in dB. It is typically between about **17 and 35 dB**.
- **VSWR:** The VSWR or voltage standing wave ratio indicates how good the match is to the required impedance level. VSWR levels of between **1:1.2 and 1:1.5** are typically achieved.

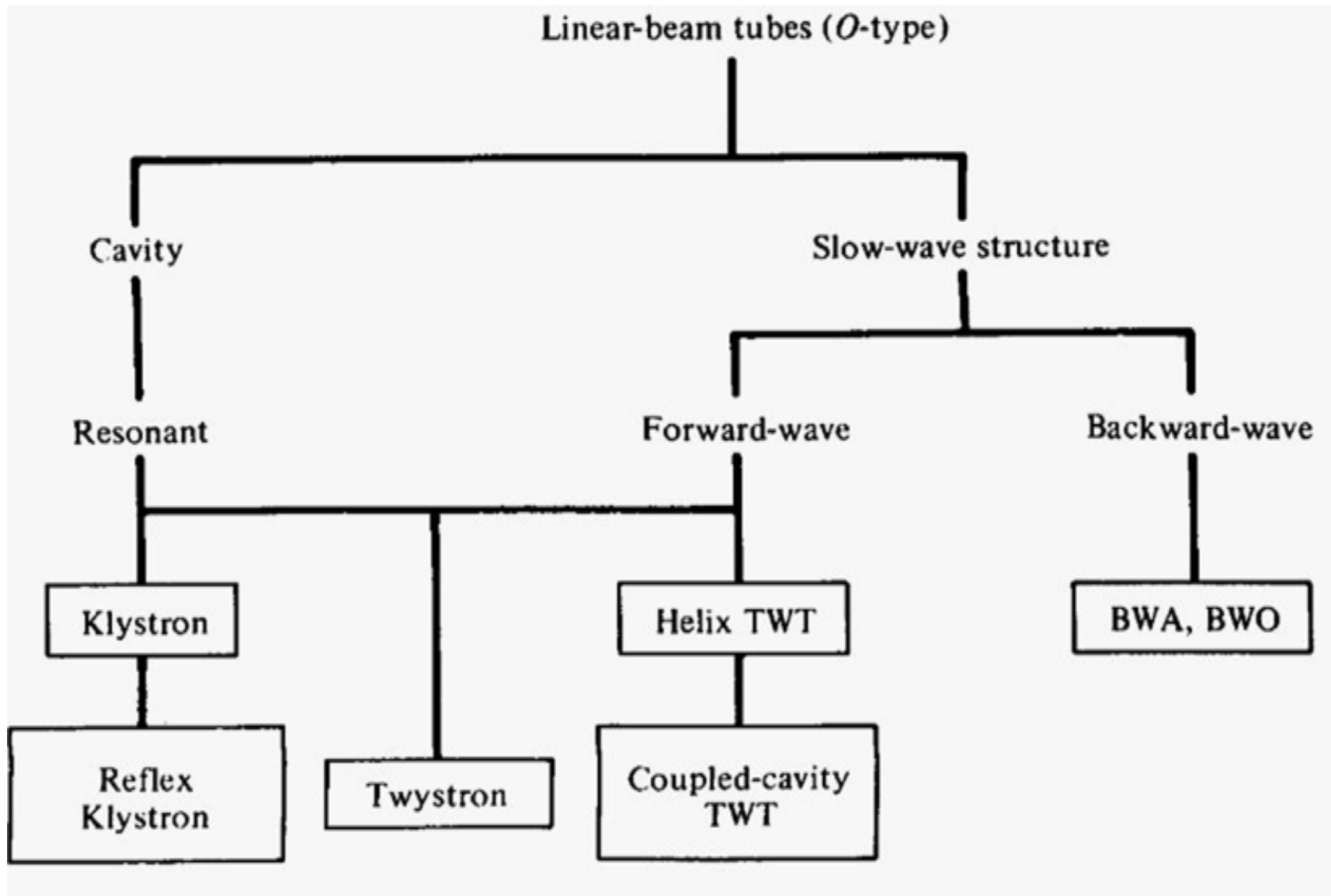




# Microwave Tubes

- The conventional vacuum tubes, such as triodes, tetrodes, and pentodes, are still used as signal sources of **low output power at low microwave frequencies**.
- The most important microwave tubes at present are the linear-beam tubes (O type).
- The paramount O - type tube is the two-cavity klystron, and it is followed by the reflex klystron.

- The helix Traveling-Wave Tube (TWT), the coupled-cavity TWT, the Forward-Wave Amplifier (FWA), and the Backward-Wave Amplifier and Oscillator (BWA and BWO) are also 0 -type tubes.
- But they have non-resonant periodic structures for electron interactions.



- In O – type tube a magnetic field whose axis coincides with that electron beam is used to hold the beam together as it travels the length of the tube. It is also called as **Linear Beam Tube**.
- Klystrons and TWT's are linear beam or O type tubes in which the **accelerating electric field in the same direction as the static magnetic field used to focus the electron beam.**

# Klystrons

- A klystron is a vacuum tube that can be used either **as a generator** or as **an amplifier** of power at microwave frequencies.
- This was invented by Russel H. Varian at Stanford University in 1939 in association with his brother S.P. Varian.

# Two Cavity Klystron Amplifier

- widely used microwave amplifier operated by the **principles of VELOCITY and CURRENT MODULATION.**
- All electrons injected from the cathode arrive at the first cavity with uniform velocity.
- Those electrons passing the first cavity gap at
  - zeros of the gap voltage (or signal voltage) pass through with unchanged velocity;
  - those passing through the positive half cycles of the gap voltage undergo an increase in velocity;
  - those passing through the negative swings of the gap voltage undergo a decrease in velocity.

- As a result of these actions, the electrons gradually bunch together as they travel down the drift space.
- The variation in electron velocity in the drift space is known as “**Velocity Modulation**”.
- The density of the electrons in the second cavity gap varies cyclically with time.
- The electron beam contains an ac component and is said to be current-modulated.
- The maximum bunching should occur approximately midway between the second cavity grids during its retarding phase; thus the kinetic energy is transferred from the electrons to the field of the second cavity.

- The electrons then emerge from the second cavity with reduced velocity and finally terminate at the collector.
- The characteristics of a two-cavity klystron amplifier are as follows:
  - 1. **Efficiency: about 40%.**
  - 2. Power output: average power (CW power) is up to 500 kW and pulsed power is up to 30 MW at 10 GHz.
  - 3. **Power gain: about 30 dB.**

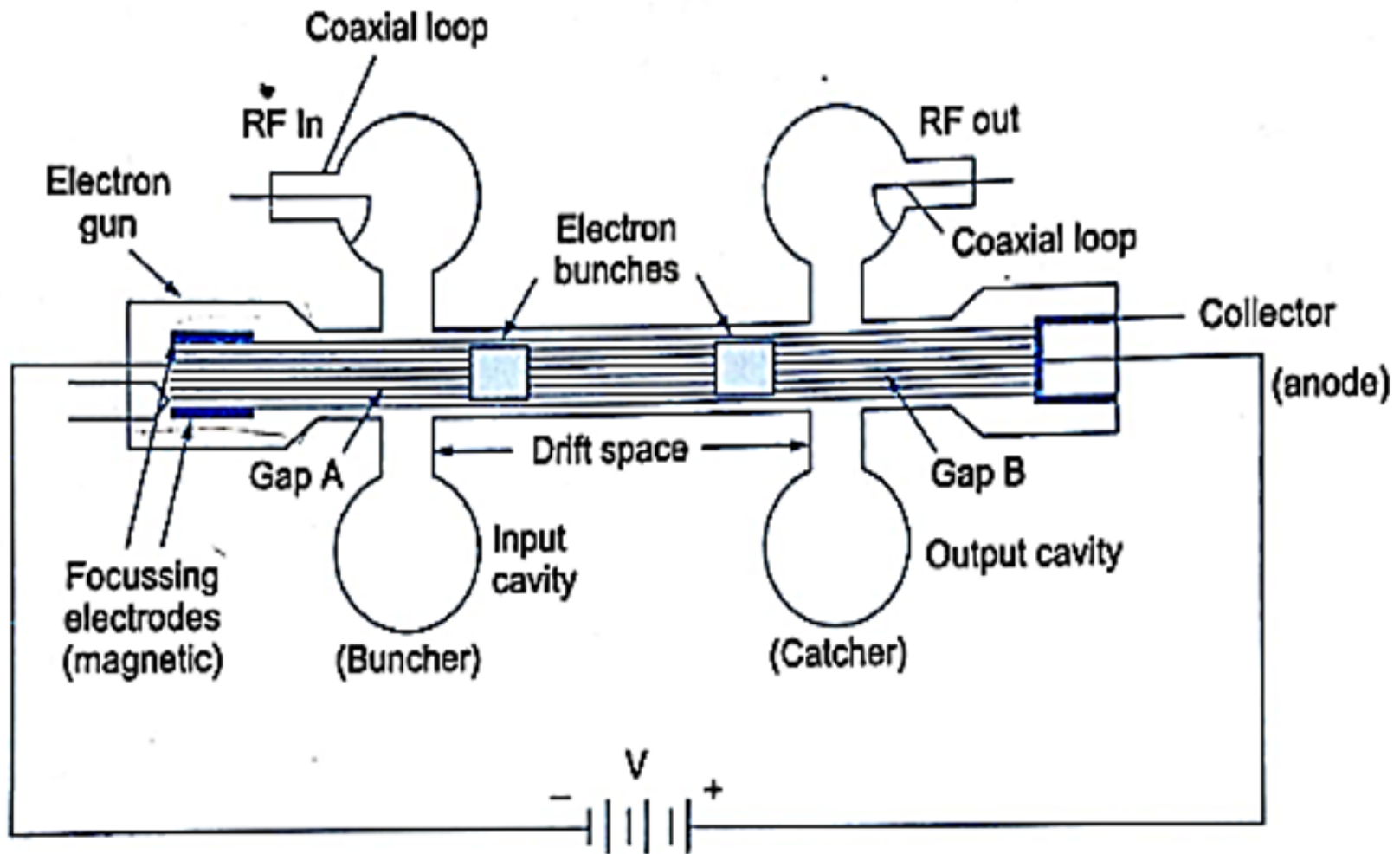


Fig. Two cavity klystron amplifier

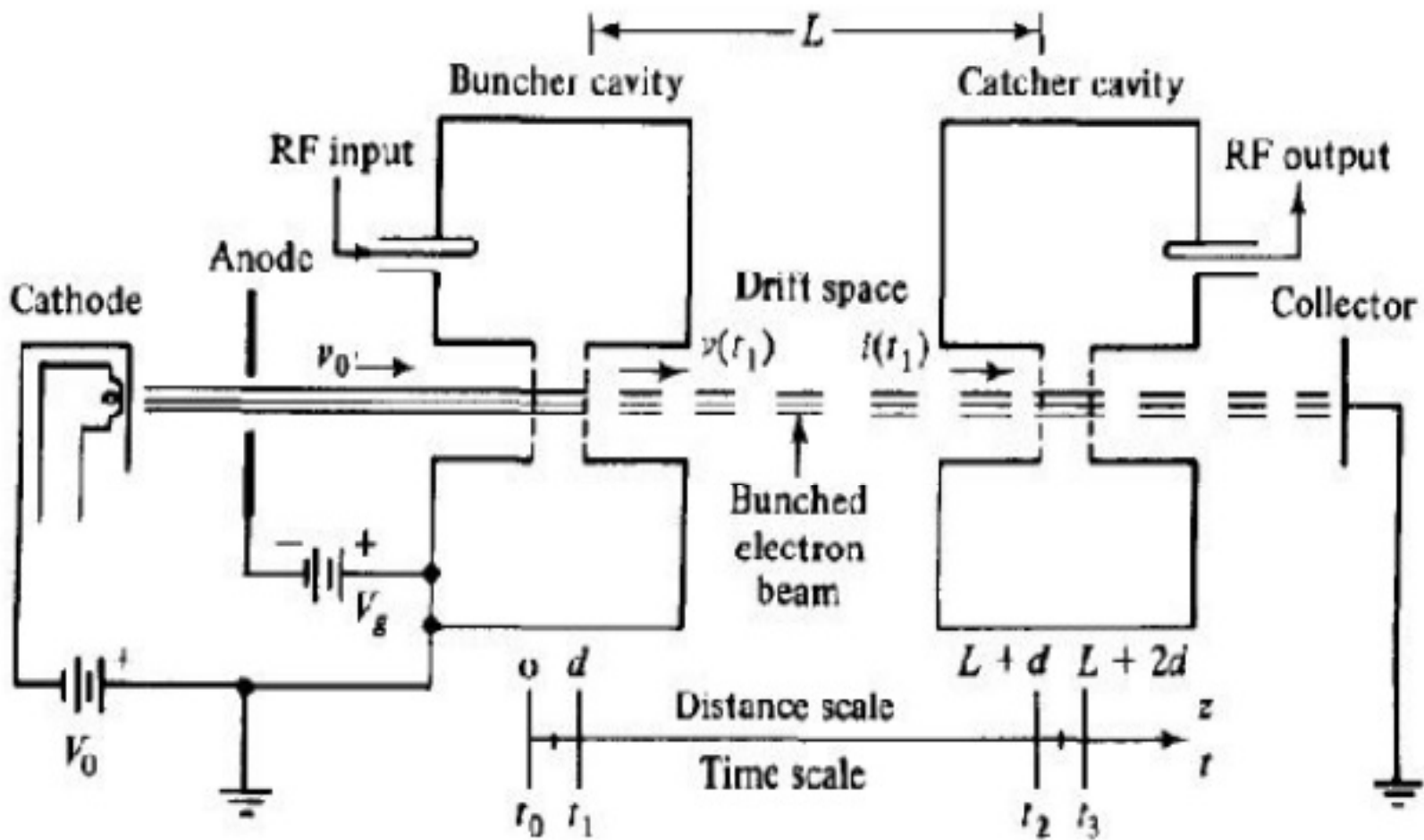


Figure 9-2-2 Two-cavity klystron amplifier.

- A two-cavity klystron amplifier is shown in Fig. which is basically a **velocity is modulated tube**.
- Here high velocity electron beam is formed, focused and sent down along a glass tube through an input cavity (buncher), a field free drift space and an output cavity (catcher) to collector electrode/anode.
- The anode is kept at a positive potential with respect to cathode.
- The electron beam passes through a gap 'A' consisting of two grids of the buncher cavity separated by a very small distance and two other grids of the catcher cavity with small gap 'B'.
- The input and output are taken from the tube via resonant cavities with the aid of coupling loops.

# Operation

- The RF signal to be amplified is used for exciting the input buncher cavity thereby developing an alternating voltage of signal frequency across the gap A.
- Let us now consider the effect of this gap voltage on the electron beam passing through gap A.
- At point B' on the input RF cycle, the alternating voltage is zero and going positive.
- At this instant, the electric field across gap A is zero and an electron which passes through gap A at this instant is unaffected by the RF signal.
- Let this electron be called the reference electron  $e_R$

- Which travels with an unchanged velocity  $v_0 = \sqrt{2eV/m}$
- Where  $V$  is the anode to cathode voltage.
- An early electron  $e_e$  that passes the gap 'A' slightly before the reference electron  $e_R$  is subjected to a maximum negative field.
- Hence this early electron is decelerated and travels with a reduced velocity  $v_0$ .
- This electron  $e_e$  falls back and reference electron  $e_R$  catches up with the early electron.

- Therefore, the velocity of electron varies in accordance with RF input voltage, resulting in velocity modulation of the electron beam.
- As a result of these actions, the electrons in the bunching limit (between points 'A" and 'C") gradually bunch together as they travel down the drift space, from gap A to gap B.
- The pulsating stream of electrons passes through gap Band excites oscillations in the output cavity (catcher).
- The density of electrons passing the gap B vary cyclically with time, that is the electron beam contains an ac current and is current modulated.
- The drift space converts the velocity modulation into current modulation.

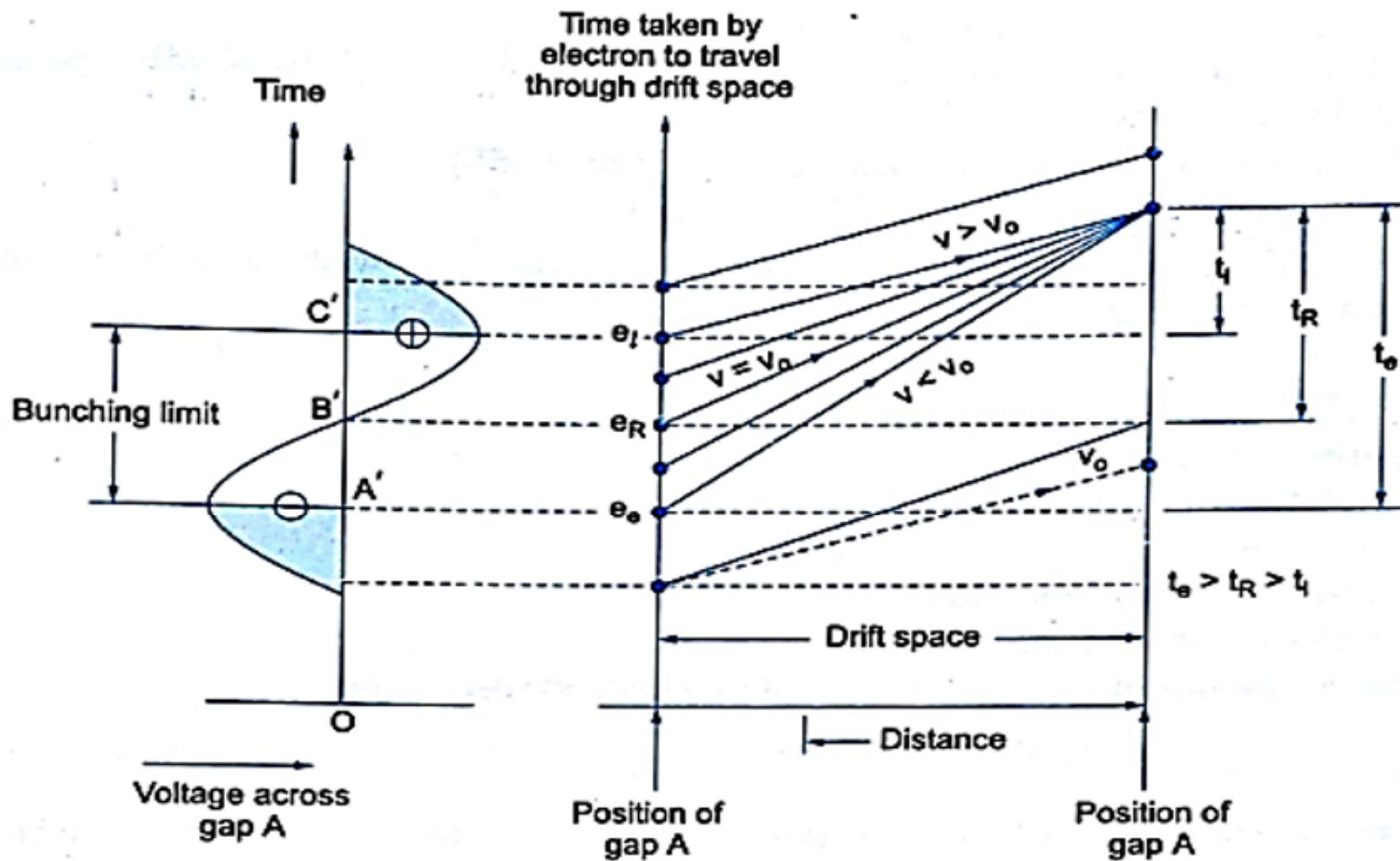


Fig. Apple gate diagram of a klystron amplifier

- Bunching occurs only once per cycle centered around the reference electron.
- With proper design (optimum gap widths, anode to cathode voltage, drift space length etc.), a little RF power applied to the buncher cavity results in large beam currents at the catcher cavity with a considerable power gain.

# Performance Characteristics

- Frequency: 250 MHz to 100 GHz (60 GHz nominal).
- Power: 10kW - 500 kW (CW) 30 MW (Pulsed).
- Power gain: 15 dB - 70 dB (60 dB nominal).
- Bandwidth: 10 - 60 MHz
- Noise figure: 12 - 20 dB
- Theoretical efficiency: 58% (30% - 40% nominal).

# Applications

- As power output tubes
  - a. In UHF TV transmitters.
  - b. In troposphere scatter transmitters.
  - c. Satellite Communication ground stations.
  - d. Radar transmitters.
  - As power oscillator (5 - 50 GHz) if used as a klystron amplifier.

# Reflex Klystron

- two-cavity klystron oscillator is usually not constructed because, when the oscillation frequency is varied, the resonant frequency of each cavity and the feedback path phase shift must be readjusted for a positive feedback.
- The reflex klystron is a single-cavity klystron that overcomes the disadvantages of the two cavity klystron oscillator.

- It is a low-power generator of 10 to 500-mW output at a frequency range of 1 to 25 GHz.
- The **efficiency is about 20 to 30%**.
- This type is widely used in the laboratory for microwave measurements and in microwave receivers
  - as local oscillators in commercial, military, and airborne Doppler radars as well as missiles.
- The reflex klystron is a single cavity variable frequency microwave generator of low power and low efficiency.

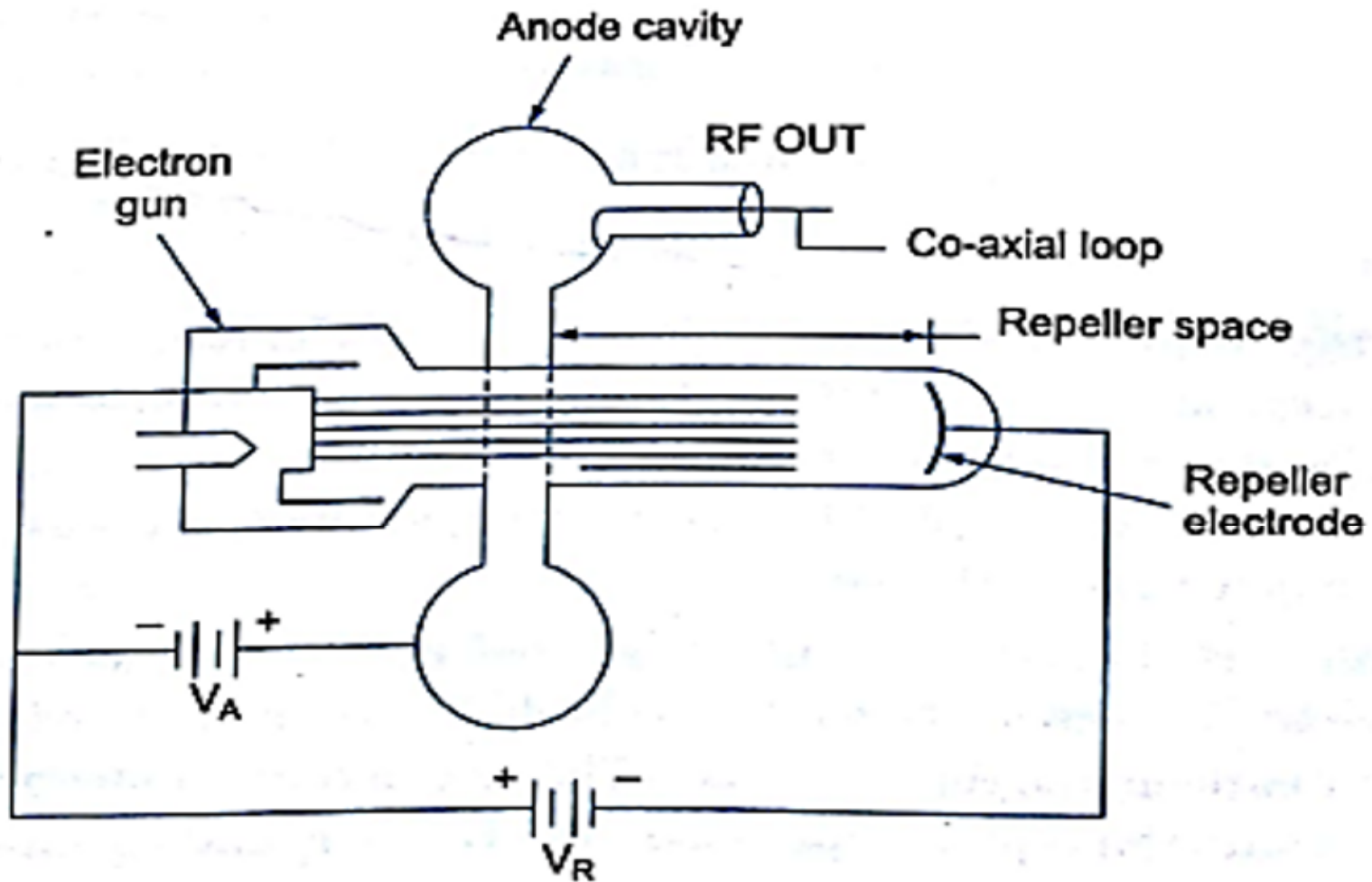
- The electron beam injected from the cathode is first velocity-modulated by the cavity-gap voltage.
- Some electrons accelerated by the accelerating field enter the repeller space with greater velocity than those with unchanged velocity.
- Some electrons decelerated by the retarding field enter the repeller region with less velocity.

- All electrons turned around by the repeller voltage then pass through the cavity gap in bunches that occur once per cycle.
- On their return journey the bunched electrons pass through the gap during the retarding phase of the alternating field and give up their kinetic energy to the electromagnetic energy of the field in the cavity.
- Oscillator output energy is then taken from the cavity. The electrons are finally collected by the walls of the cavity or other grounded metal parts of the tube.

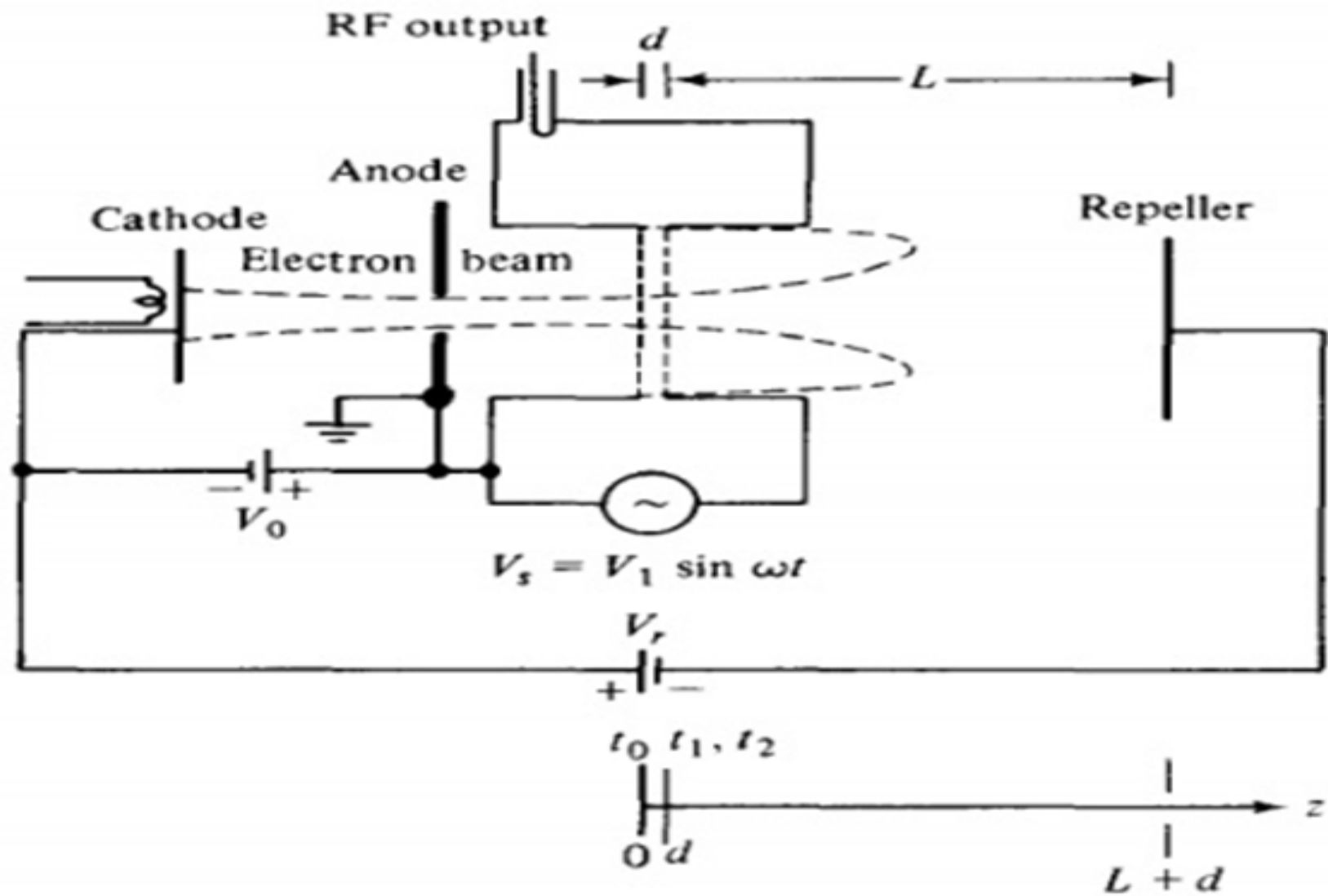
# Construction

- It consists of an electron gun, a filament surrounded by cathode and a focusing electrode at cathode potential as shown in Fig.
- The electron beam is accelerated towards the anode cavity (positive potential).
- After passing the gap in the cavity; electrons travel towards a repeller electrode which is at a high negative potential  $V_R$ .

- The electrons never reach the repeller because of the negative field and are returned back towards the gap.
- Under suitable conditions, the electrons give more energy to the gap than they took from the gap on their forward journey and oscillators are sustained.

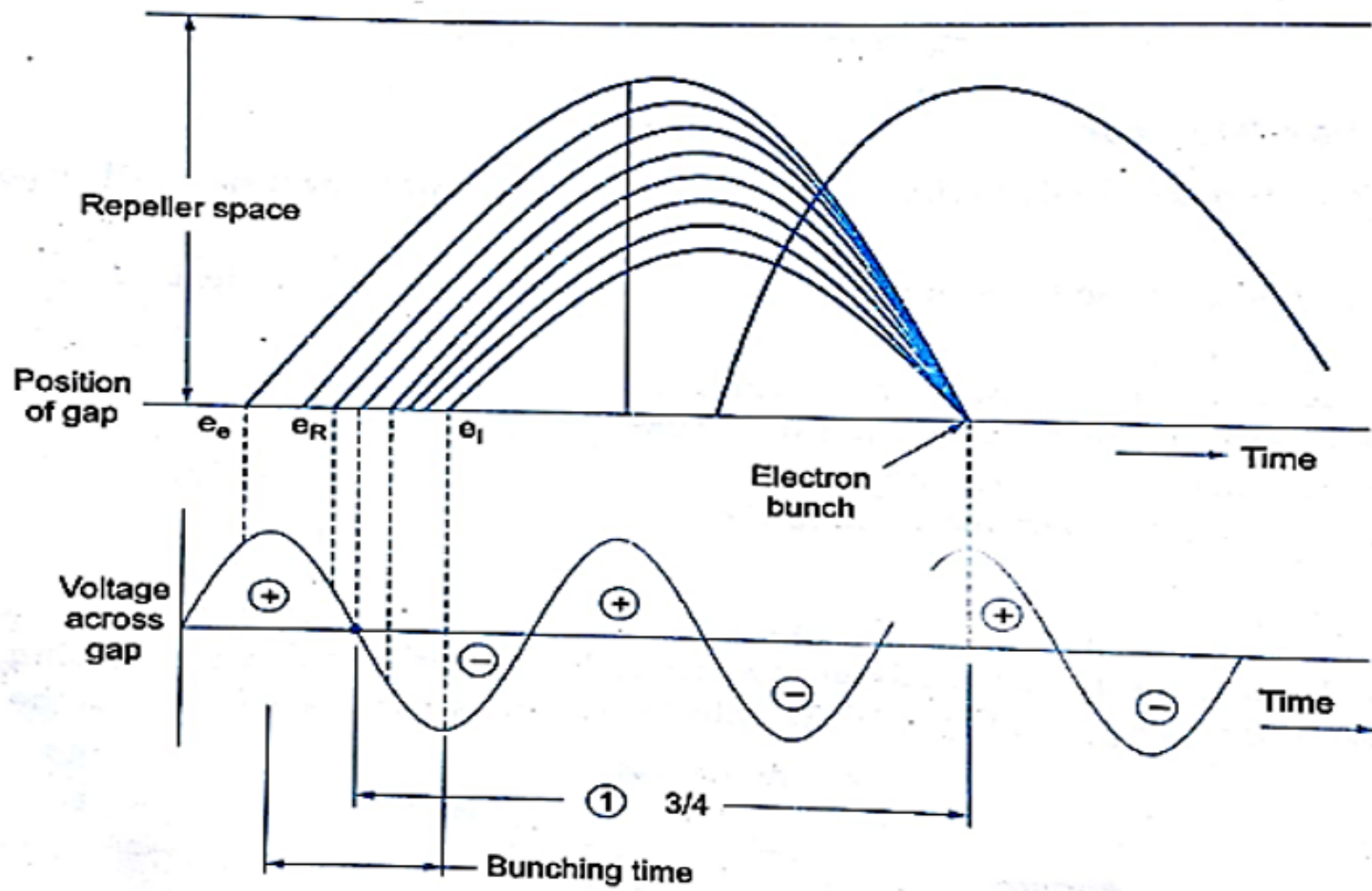


**Fig. Constructional details of reflex klystron**



# Operation

- It is assumed that oscillators are set up in the tube due to noise or switching transients and these oscillations are assumed by device operation.
- The RF voltage that is produced across the gap by the cavity oscillations, act on the electron beam to cause velocity modulation.
- $eR$  is the reference electron passes through the gap when the gap voltage is 0 and going negative.



**Fig. Applegate diagram**

- Electron  $e_R$  is unaffected by the gap voltage. This moves towards the repeller and gets reflected by the negative voltage on the repeller.
- It returns and passes through the gap for second time.
- The early electron  $e_R$  that passes through the gap before the reference electron  $e_R$  experiences a max positive voltage across the gap and this electron is accelerated.
- It moves with greater velocity and penetrates deep into repeller space.

- The return time for electron  $e_e$  is greater as the depth of penetration into the repeller space is more.
- Hence  $e_e$  and  $e_R$  is greater as the depth of penetration into the repeller space is more.
- Hence  $e_e$  and  $e_R$  appears at the gap for the second time at the same instant.

- The late electron  $e_l$  that passes the gap later than reference electron  $e_R$  experiences a maximum negative voltage and moves with a retarding velocity.
- The return time is shorter as the penetration into repeller space is less and catches up with  $e_R$  and  $e_e$  electrons forming a bunch.
- Bunches occur once per cycle centered on the reference electron  $e$  and these bunches transfer maximum energy to the gap to get sustained oscillations.

- For oscillations to be sustained, the time taken by the electrons to travel into the repeller space and back to the gap (called transit time) must have an optimum value.
- This factor is not important in a klystron amplifier but it assumes a great importance here.

- The most optimum departure time is obviously centered on the reference electron which is at  $180^\circ$  point of sine wave voltage across the resonator gap.
- The cavity resonator spends energy in accelerating the electrons and gains energy in retarding them.
- As there are as many retarded electrons as accelerated the total energy outlay is nil.

- it is clear that the best possible time for electrons to return to the gap is at a time at which the voltage then existing across the gap will apply maximum retardation to them.
- This is when the gap voltage is positive maximum.
- This causes electrons to fall through the maximum negative voltage between the gap grids, thus giving up the maximum amount of energy to the gap.
- Thus it appears that the best time for electrons to return to the gap is at the  $90^\circ$  point of sine wave gap voltage.

- Returning of electrons after  $1 \frac{3}{4}$  or  $2 \frac{3}{4}$  or  $3 \frac{3}{4}$  cycles etc. satisfies the above requirements. In general, the optimum transit time should be
- $$T = n + \frac{3}{4}$$
  - Where n is any integer. This depends on repeller and anode voltage.

# Applications

- In radar receivers.
- Local oscillator in microwave receivers
- Signal source in microwave generator of variable frequency.
- Portable microwave links.
- Pump oscillator in parametric amplifier.

# Characteristics

- Frequency: 4 to 200 GHz
- Power: 1.0 mW to 2.5 W
- Theoretical  $\eta$  : 22.75%
- Practical  $\eta$  : 10% to 20%
- Tuning range: 5 GHz at 2 W to 30 GHz at 10 mW.



# TRAVELING WAVE TUBE

- Kompfner invented the helix traveling-wave tube (TWT) in 1944.
- For broadband applications, the helix TWTs is almost exclusively used, whereas for high-average-power purposes, such as radar transmitters, the coupled-cavity TWTs are commonly used.

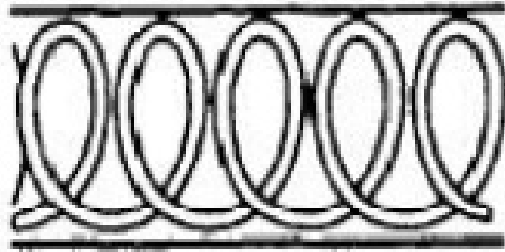
# Comparison

- In the case of the TWT, the microwave circuit is non-resonant and the wave propagates with the same speed as the electrons in the beam.
- The initial effect on the beam is a small amount of velocity modulation caused by the weak electric fields associated with the traveling wave.

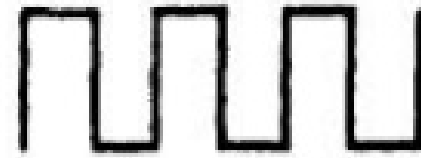
- Just as in the klystron, this velocity modulation later translates to current modulation, which then induces an RF current in the circuit, causing amplification.
- However, there are some major differences between the TWT and the klystron:

- The interaction of electron beam and RF field in the TWT is continuous over the entire length of the circuit, but the interaction in the klystron occurs only at the gaps of a few resonant cavities.
- The wave in the TWT is a propagating wave; the wave in the klystron is not.
- In the coupled-cavity TWT there is a coupling effect between the cavities, whereas each cavity in the klystron operates independently.

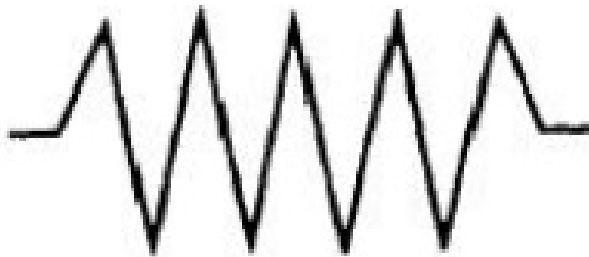
- As the operating frequency is increased, both the inductance and capacitance of the resonant circuit must be decreased in order to maintain resonance at the operating frequency.
- Because the gain-bandwidth product is limited by the resonant circuit, the ordinary resonator cannot generate a large output.
- Several non-resonant periodic circuits or slow-wave structures (see Fig) are designed for producing large gain over a wide bandwidth.



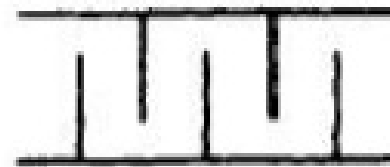
(a)



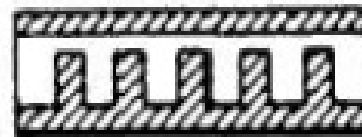
(b)



(c)



(d)



(e)

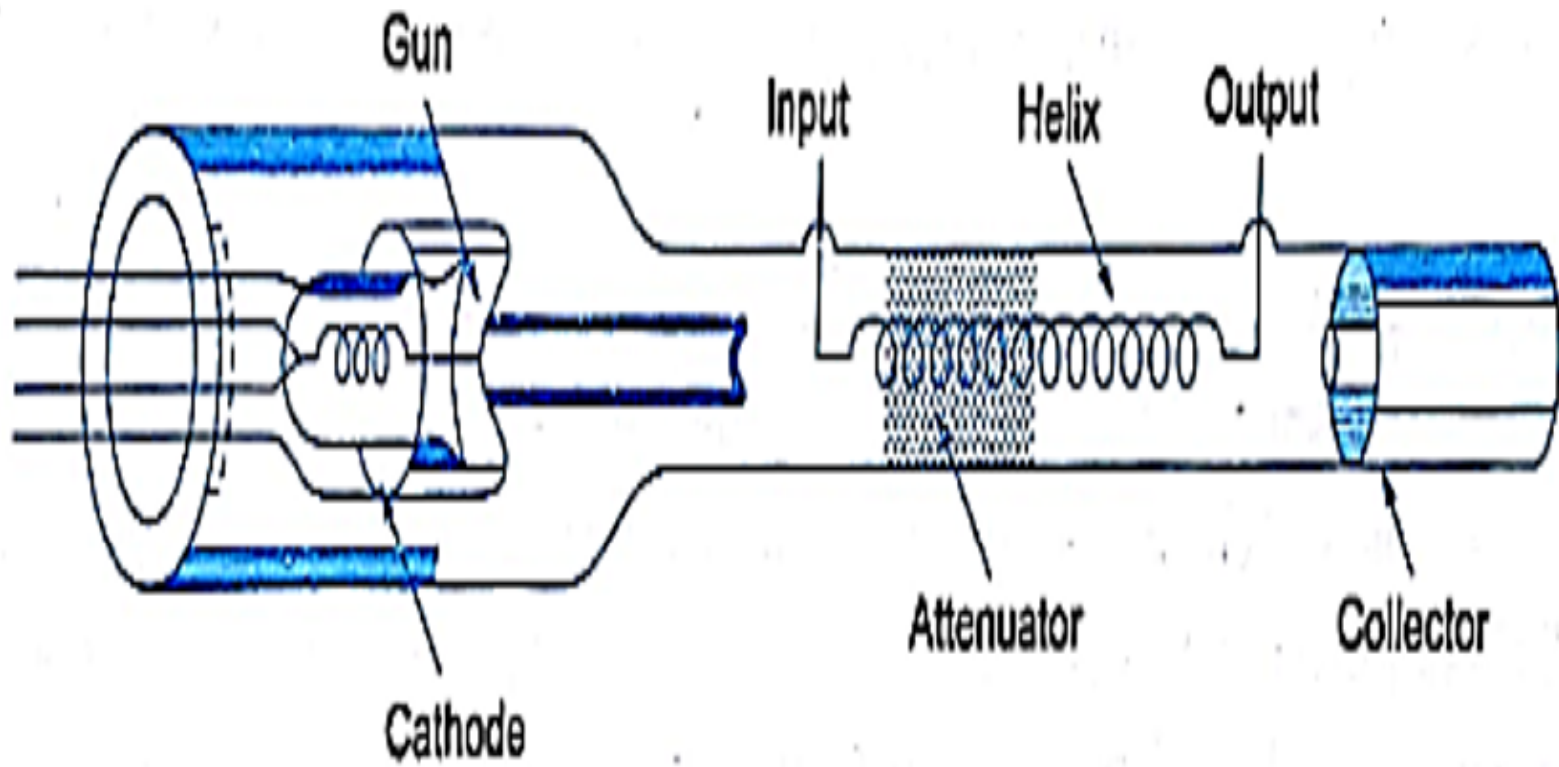
- Klystrons are essentially narrow band devices as they utilize cavity resonators to velocity modulate the electron beam over a narrow gap whereas TWT's are broad band devices in which there are no cavity resonators.
- The interaction space in a TWT is extended and the electron beam exchanges energy with the RF wave over the full length of the tube.

- The TWT makes use of distributed interaction between an electron beam and a travelling wave.
- To prolong the interaction between an electron beam and the RF field it is necessary to ensure that they are both traveling in the same direction with nearly the same velocity.
- Thus, it differs from the klystron in which the electron beam travels and the RF field remains stationary.
- The electron beam travels with a velocity governed by the anode voltage (typically  $0.1 V_c$  where  $V_c$  is the velocity of light in vacuum).
- The RF field propagates with a velocity equal to velocity of light  $V_c$  .

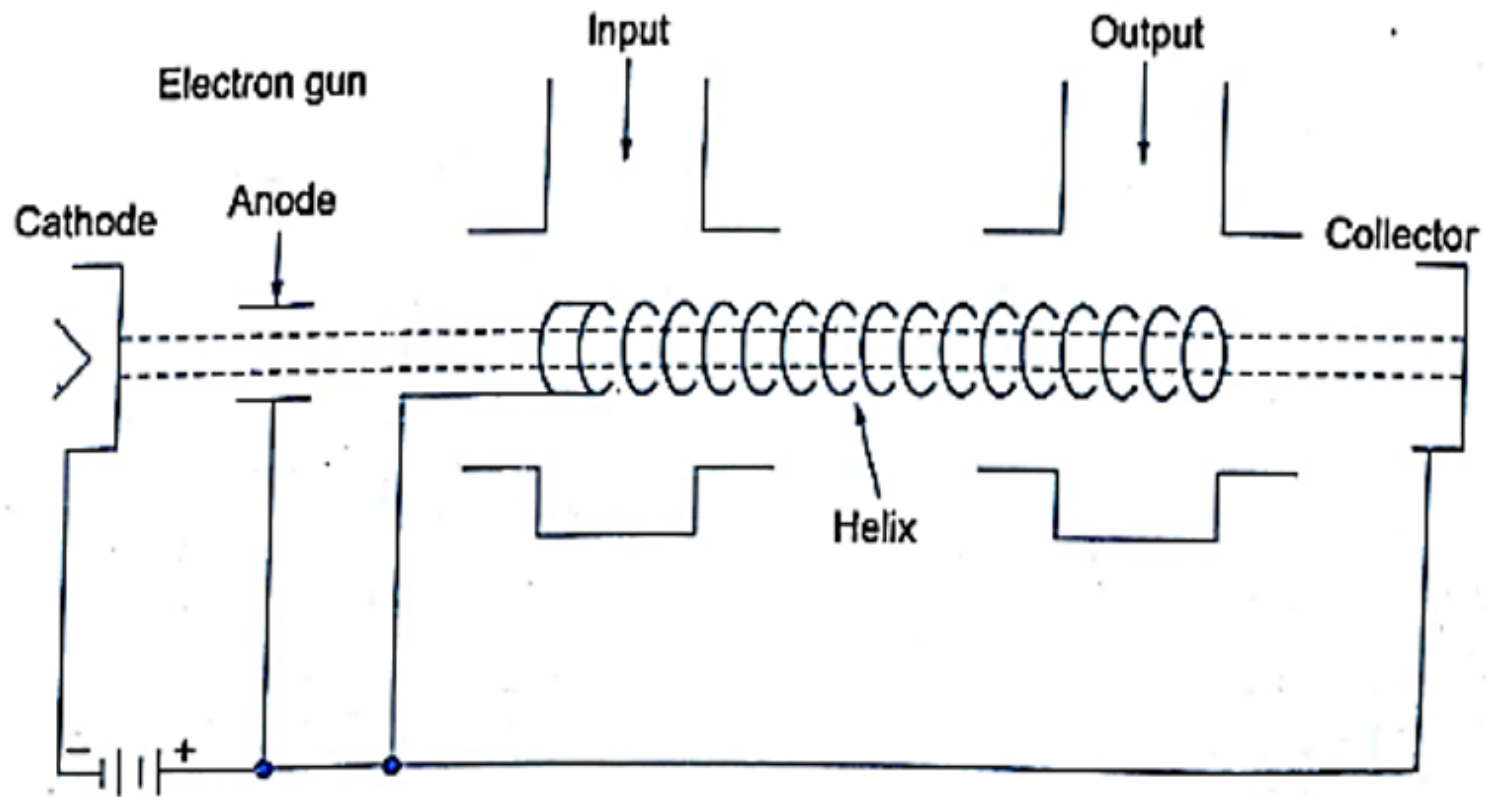
# Constructional Features of TWT

- The physical construction of a typical TWT along with the schematic electrode arrangement is shown in Fig.
- It has an electron gun as used in klystrons, which is used to produce a narrow constant velocity electron beam.
- This electron beam is in turn passed through the center of a long axial helix.
- A magnetic focusing field is provided to prevent the beam from spreading and to guide it through the center of the helix.
- Helix is a loosely wound thin conducting helical wire, which acts as a slow wave structure.

- The signal to be amplified is applied to the end of the helix adjacent to the electron gun.
- The amplified signal appears at the output or other end of the helix under apocopate operating conditions.



(a)



(b)

**Fig. (a) Physical construction of TWT (b) schematic electrode arrangement.**

# Operation

- When the applied RF signal propagates around the turns of the helix, it produces an electric field at the center of the helix.
- The RF field propagates with velocity of light.
- The axial electric field due to RF signal travels with velocity of light multiplied by the ratio of helix pitch to helix circumference.
- When the velocity of the electron beam traveling through helix approximates the rate of advance of the axial field, then interaction takes place between them in such a way that on an average the electron beam delivers energy to the RF wave on the helix.

- Thus, the signal wave grows and amplified output is obtained at the output of the TWT. The axial phase velocity  $v_p$  is given by,

$$V_p = V_c (\text{Pitch} / 2\pi r)$$

- Where  $r$  is the radius of the helix and is essentially constant over a range of frequencies and this characteristic of helix slow wave structure enables TWT to have broadband operation.
- Helix, since it provides the least change in  $V_p$  with frequency, is preferred over other slow wave structures for TWT.

- The TWT may be thought of as a limiting case of the multicavity klystron which has a very large number of closely spaced gaps with a phase change that propagates from left to right at approximately the same velocity as the electron beam.
- When the axial field is zero, electron velocity is unaffected.

- This happens at the point of node of the axial electric field.
- At a point where the axial field is positive antinode, the electron coming against it is accelerated and tries to catch up with the later electron which encounters the nodal RF axial field.
- At a later point where the axial RF field is negative antinode, the electrons referred before tend to overtake.

- The electrons get velocity modulated. As a result of energy transfer from the electron to the RF field in phase with the RF field at the axis, a second wave is induced on the helix.
- This produces an axial electric field that lags behind the original electric field by  $\lambda/4$ . Bunching continues to take place.
- The electrons in the bunch encounter retarding field and deliver energy to the wave on the helix.
- The output becomes larger than the input and amplification results. Thus, the energy increase in the RF is a continuous process.

# Performance Characteristics

- Frequency: 0.4 to 95 GHz
- Power Outputs:
  - 5 mW (10 - 40 GHz) (Low power TWT)
  - 250 kW (CW) at 3 GHz (High power TWT)
  - 10 MW (pulsed) at 3 GHz
- Efficiency: 5 to 20 % (30% with depressed collector)
- Noise figure:
  - 4 - 6 dB (Low power TWT 0.5 to 16 GHz)
  - 25 dB (High power TWT at 40 GHz)

TWT	KLYSTRON
In case of TWT the field travels along with the electron beam.	Field is stationary only electron beam travels.
The interaction of the electron beam and the RF field is continuous over the entire length.	In this case the interaction takes place only at the gaps of a few resonant cavity.
The input wave in TWT is propagating wave The TWT is a non resonating microwave circuit.	The input wave is not propagating wave Klystron is a resonating microwave circuit.

# M-type Tubes

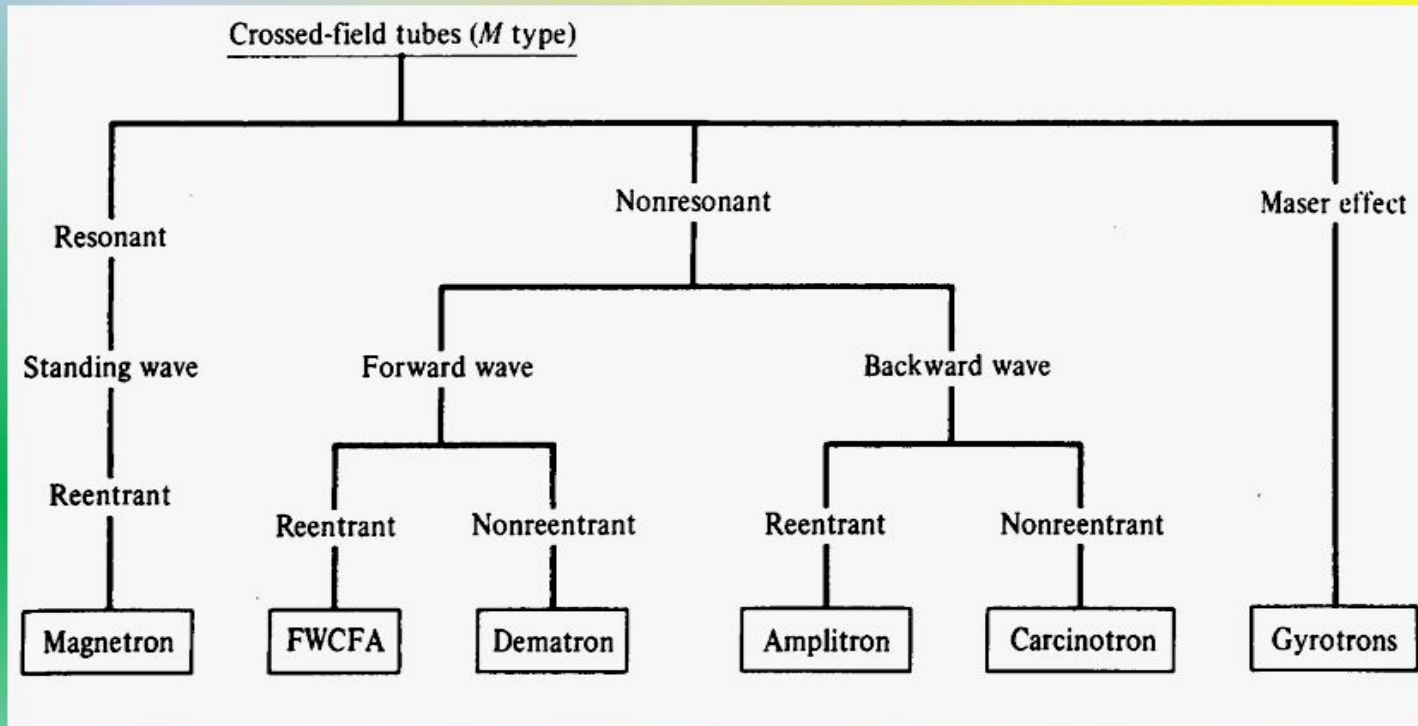
- Also called as **Crossed Field Microwave Tubes**, in **which dc electric field is perpendicular to the dc magnetic field**.
- As the name crossed field itself suggest that the fields are perpendicular to each other.
- The cavity magnetron is the main component of a microwave.
- The magnetron is an oscillator where electrons are emitted from a hot cathode and whirl past resonant cavities which are part of the anode at speeds that generate microwave energy.

- **Definition:** A magnetron is a device that generates high power electromagnetic wave. It is basically considered as a **self-excited microwave oscillator**.
- The reason behind calling it so is that the electric and magnetic field produced inside the tube are mutually perpendicular to each other thus the two crosses each other.

- Magnetron is a grouping of a simple diode vacuum tube together with built in cavity resonators and an exceptionally powerful magnet.
- There are three types of magnetrons:
  - ❖ Negative resistance type
  - ❖ Cyclotron frequency type
  - ❖ Travelling wave or Cavity type

- Negative resistance magnetrons make use of negative resistance between two anode segments.
- Cyclotron frequency magnetrons depend upon synchronism amid an alternating component of electric field and periodic oscillation of electrons in a direction parallel to this field.
- Cavity type magnetrons depend upon the interface of electrons with a rotating electromagnetic field of constant angular velocity.

- The classification of crossed-field tubes is,



# Parts of a Magnetron

- A cathode is present at the center
- A cylindrical block of copper, is fixed axially, which acts as an anode. This anode block is made of a number of slots that acts as resonant anode cavities.
- The space present between the anode and cathode is called as interaction space.
- Permanent magnet, which is placed such that the magnetic lines are parallel to cathode and perpendicular to the electric field present between the anode and cathode.
- The cavity magnetron has 8 cavities. An N-cavity magnetron has N-modes of operations. These operations depend upon the frequency and phase of oscillations.

# Construction of Magnetrons

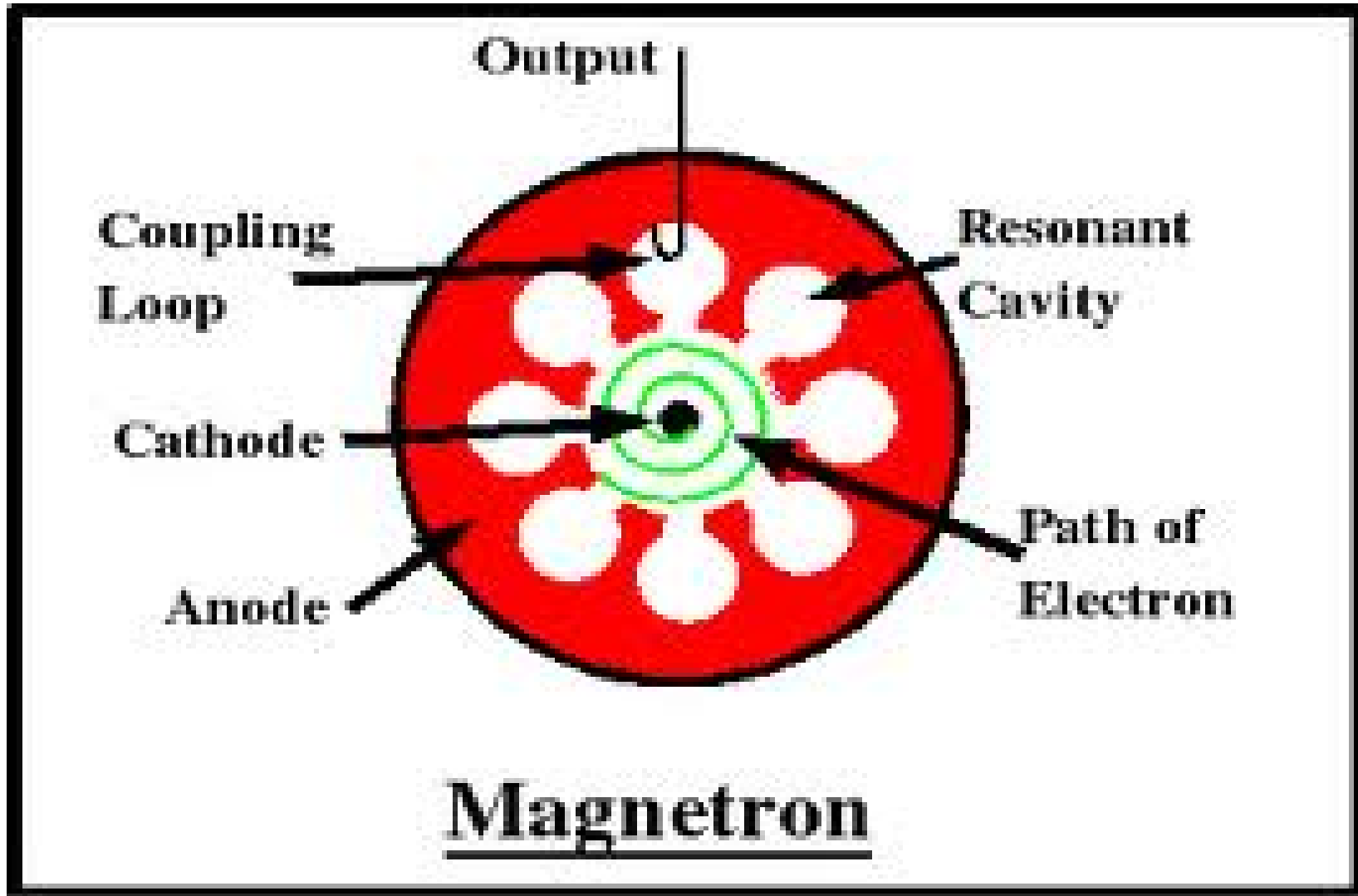
- A cylindrical magnetron has a cylindrical cathode of a certain length and radius present at the centre around which a cylindrical anode is present.
- The cavities are present at the circumference of the anode at equal spacing.
- Also, the area existing between anode and cathode of the tube is known as interaction space/region.

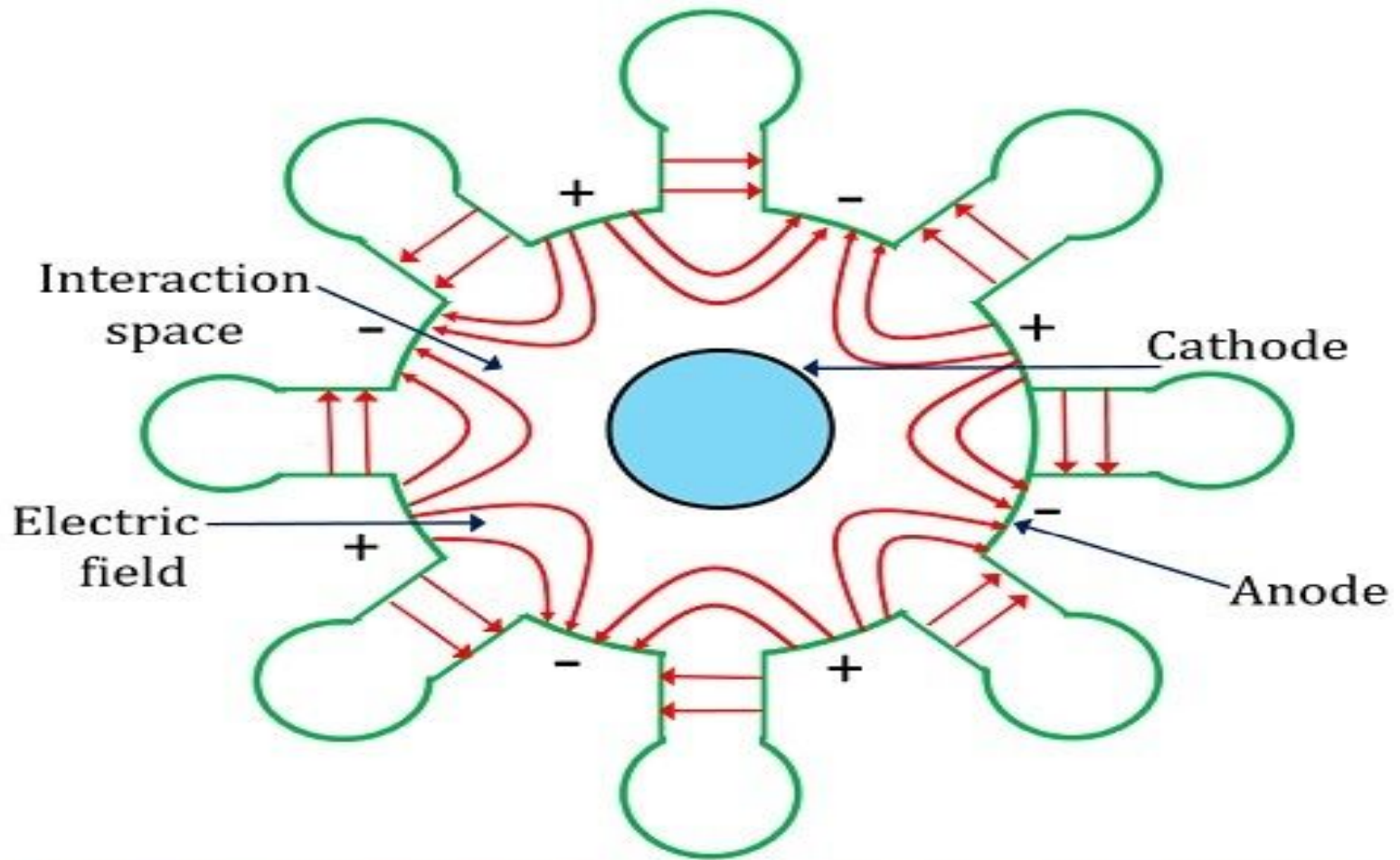
- It is to be noted here that there exists a phase difference of  $180^\circ$  between adjacent cavities. Therefore, cavities will transfer their excitation from one cavity to another with a phase shift of  $180^\circ$ .
- If one plate is positive then automatically its adjacent plate will be negative.
- that edges and cavities show  $180^\circ$  phase apart relationship.
- And the magnetic field is generated by using a permanent magnet.

# Operating Principle

- A magnetron consist of a cathode which is used to release the electrons and number of anode cavities and a permanent magnet is placed on the flipside of cathode and the space between the anode cavity and the cathode is called interacting space.
- The electrons which are emitted from the cathode moves in diverse path in the interacting space depending upon strength of electric and magnetic fields applied to the magnetron.

- A magnetron is basically a vacuum tube of high power having multiple cavities. It is also known as **Cavity Magnetron** because of the presence of anode in the resonant cavity of the tube.
- The operating principle of a magnetron is such that when electrons interact with electric and magnetic field in the cavity then high power oscillations get generated.
- Depending upon the relative strength of the magnetic and electric field the electrons released from the cavity move towards the anode will navigate through the interacting space.





**Structure of Magnetron**

Electronics Desk

# Effect of electric field only

- In the nonexistence of magnetic field ( $B=0$ ), the electrons move directly from the cathode to the anode due to the radial electric field force acting on it .
- If the magnetic field strength increases vaguely (i.e for moderate value of  $B$ ), it will apply a lateral force bending the path of electron.
- If the strength of the electrons is made adequately high enough so as to avert the electrons from reaching the anode, the anode current becomes zero.

- The magnetic field required to return electrons back to cathode just grazing the surface of the anode is called the critical magnetic field or cut-off magnetic field ( $B_c$ )
- If the magnetic field is larger than critical Magnetic field ( $B > B_c$ ), the electrons experiences a greater rotational force and may return back to cathode quite faster .This results in heating of cathode.

# Effects of magnetic fields only

- The magnetic field is applied perpendicular to electric field hence is called **Axial Magnetic Field**, therefore the magnetrons are called cross field device because of radial electric field and axial magnetic field are perpendicular to each other.
- If the magnetic field strength is more than the electrons emitted will return back to cathode with high velocity which may destroy the cathode cavity this effect is called back heating of cathode.

# Combine effect of Electric Field and Magnetic Field

- When both fields are existing in that case the electron may have dissimilar path depending upon the strength of  $E$  and  $H$ .
- If  $E > H$ , in that case the electrons reach at the anode but the path will be bend because of small magnetic field.
- If  $H > E$ , in this case the electrons return back to the cathode.

# Mechanism of Oscillation in Magnetron ( $\Pi$ mode of Oscillation)

- It is understood that the oscillation are capable of starting a device because of high quality factor.

$$Q=fc/BW$$

– (For oscillator  $BW \rightarrow 0$ , Hence  $Q \rightarrow \infty$ )

- The self oscillation can be maintained if the phase dissimilarity between anode cavity is  $N\Pi/4$  and the best result can be obtained for  $N=4$ .
- Hence, it is called ' $\Pi$ ' mode oscillation.

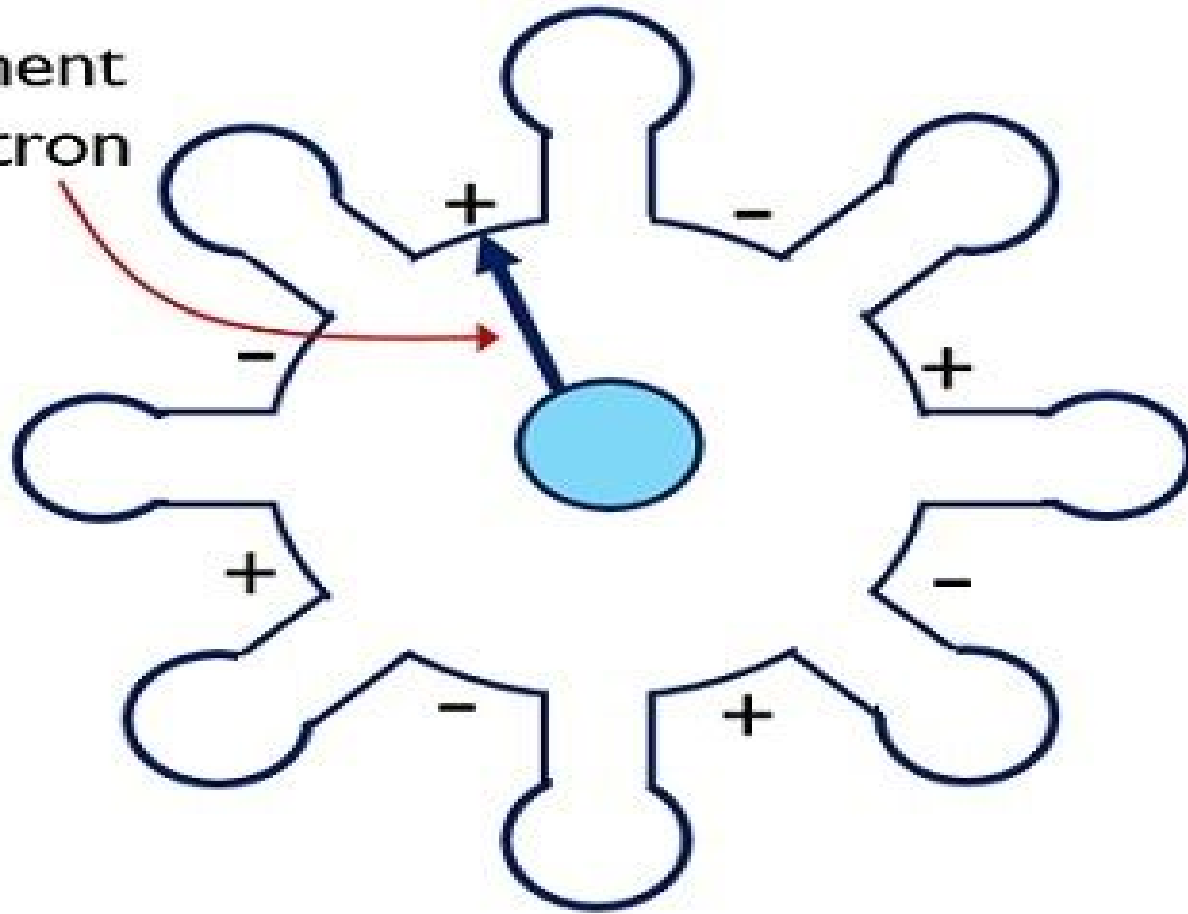
# Working of Magnetron

- **The working of magnetron is two categories.**
  - First without applying the RF input to the anode and
  - The second one with the application of RF input.

# When RF input is not present

- **Case I: When the magnetic field is 0 or absent**
- When the magnetic field is absent then the electron emerging from the cathode radially moves towards the anode. This is so because the moving electron does not experience the effect of the magnetic field and moves in a straight path.

Movement  
of electron

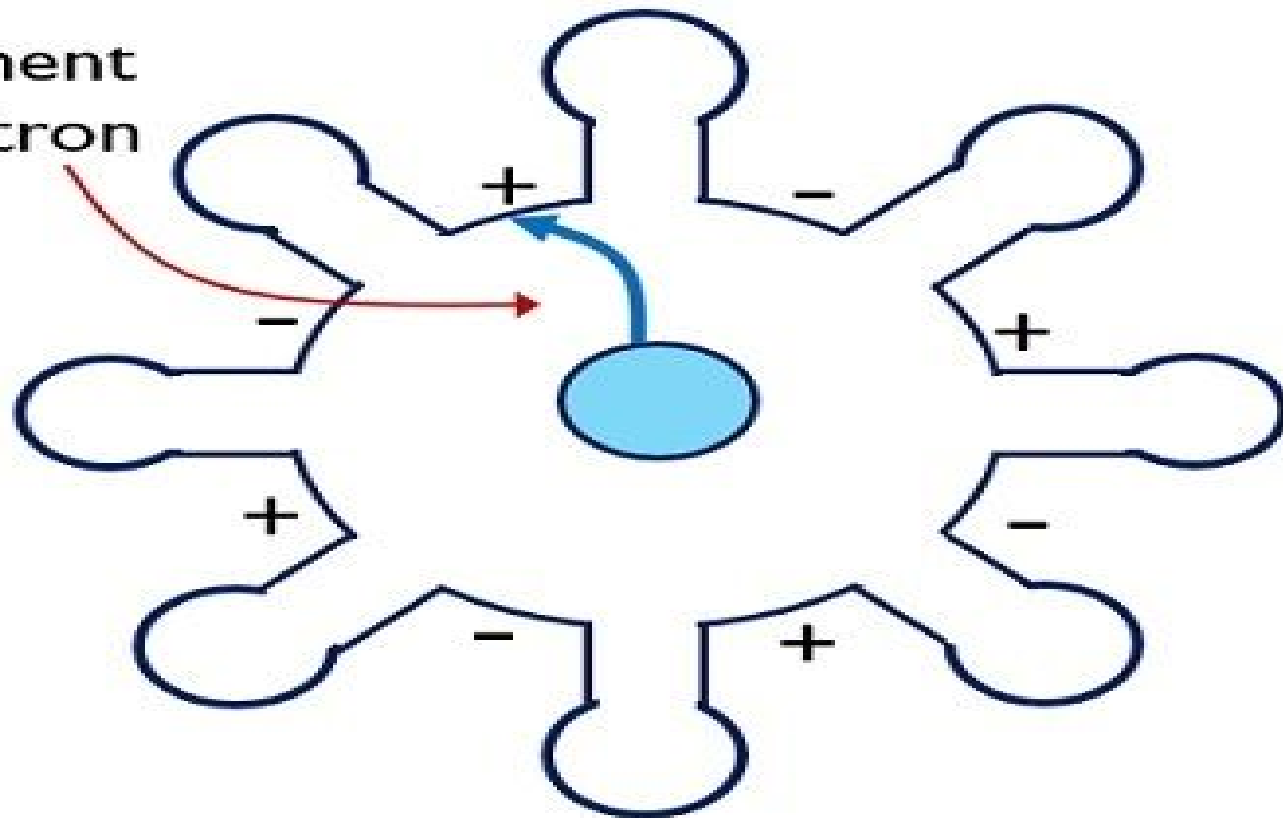


**Absence of magnetic field**

Electronics Desk

- **Case II: When a small magnetic field is present**
- In case a small magnetic field exists inside the magnetron then the electron emerging from the cathode will slightly deviate from its straight path. And this will cause a curvy motion of the electron from cathode to anode. This motion of the electron is the result of the action of electric as well as magnetic force over it.

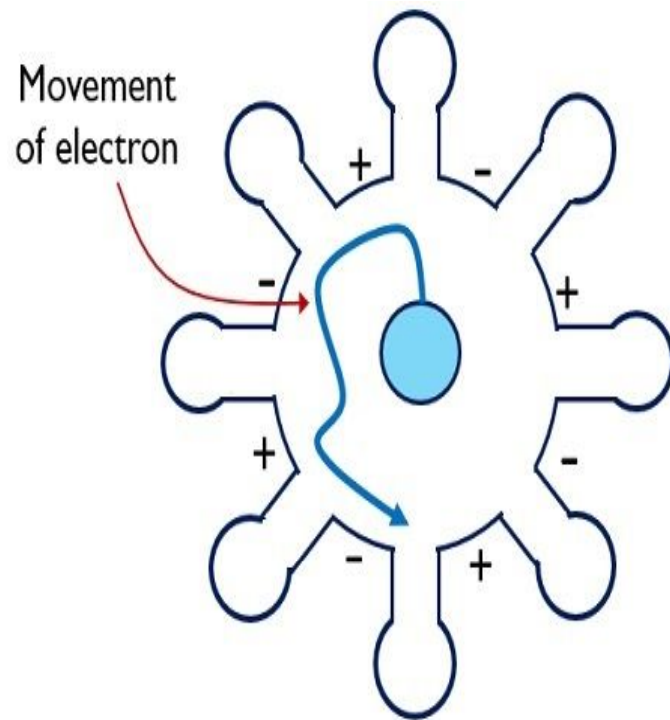
Movement  
of electron



**In presence of small  
magnetic field**

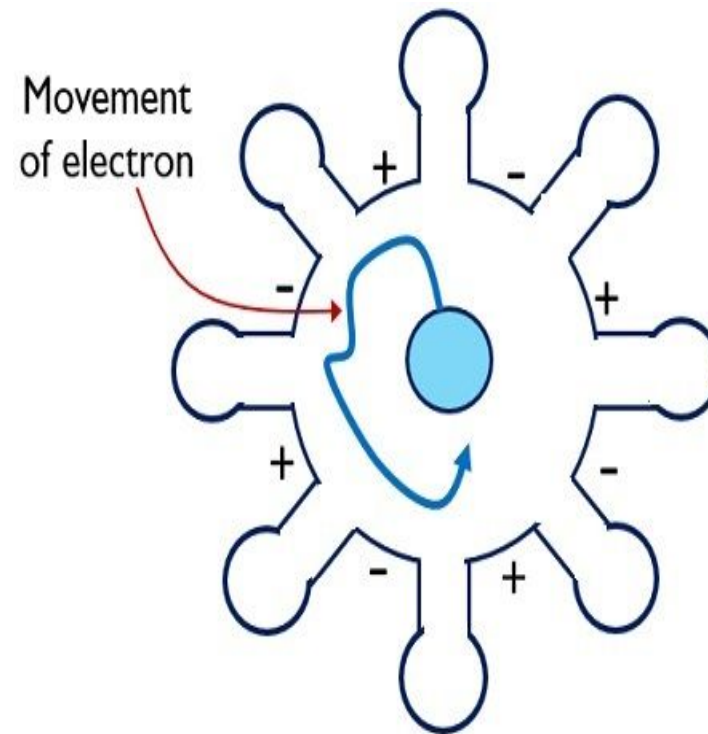
Electronics Desk

- **Case III:** In case when the magnetic field is further increased then an electron emerging from the cathode gets highly deflected by the magnetic field. And graze along the surface of the cathode. This causes the anode current to be 0. The value of the magnetic field that causes the anode current to become 0 is known as the “**critical magnetic field**”.



In presence of large magnetic field

Electronics Desk



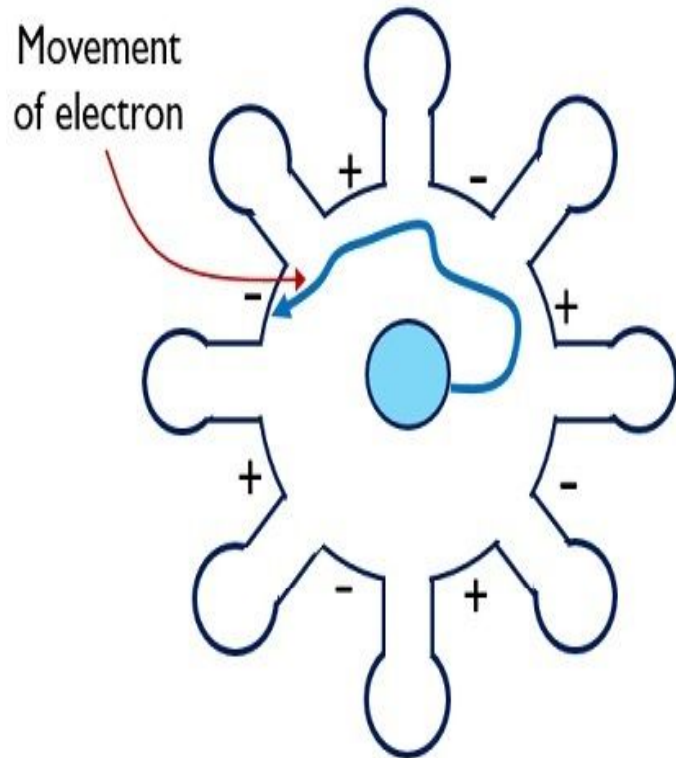
In presence of excessive magnetic field

Electronics Desk

- If the magnetic field is increased beyond the critical magnetic field, then the electron will bounce back to the cathode itself without reaching the anode. The reaching of the emitted electrons from the cathode back to it is known as back heating. So to avoid this electric supply provided to the cathode must be cut-off after oscillations have been set up in the tube.

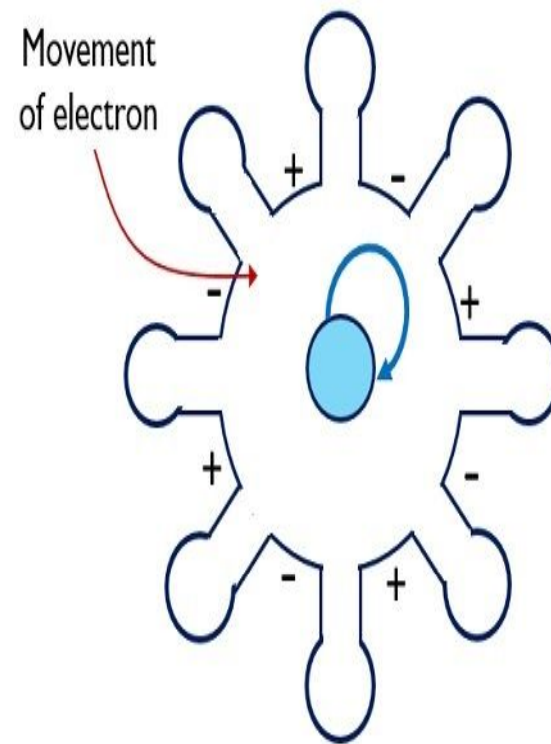
# When the RF field is present

- **Case I:** In case an active RF input is provided to the anode of the magnetron then oscillations are set up in the interaction space of the magnetron. So, when an electron is emitted from the cathode to anode then it transfers its energy in order to oscillate.
- Such electrons are called **Favored Electrons**. In this condition, the electrons will have a low velocity and thus will take a considerably high amount of time to reach from cathode to anode.



When moving electron release energy to oscillate

Electronics Desk

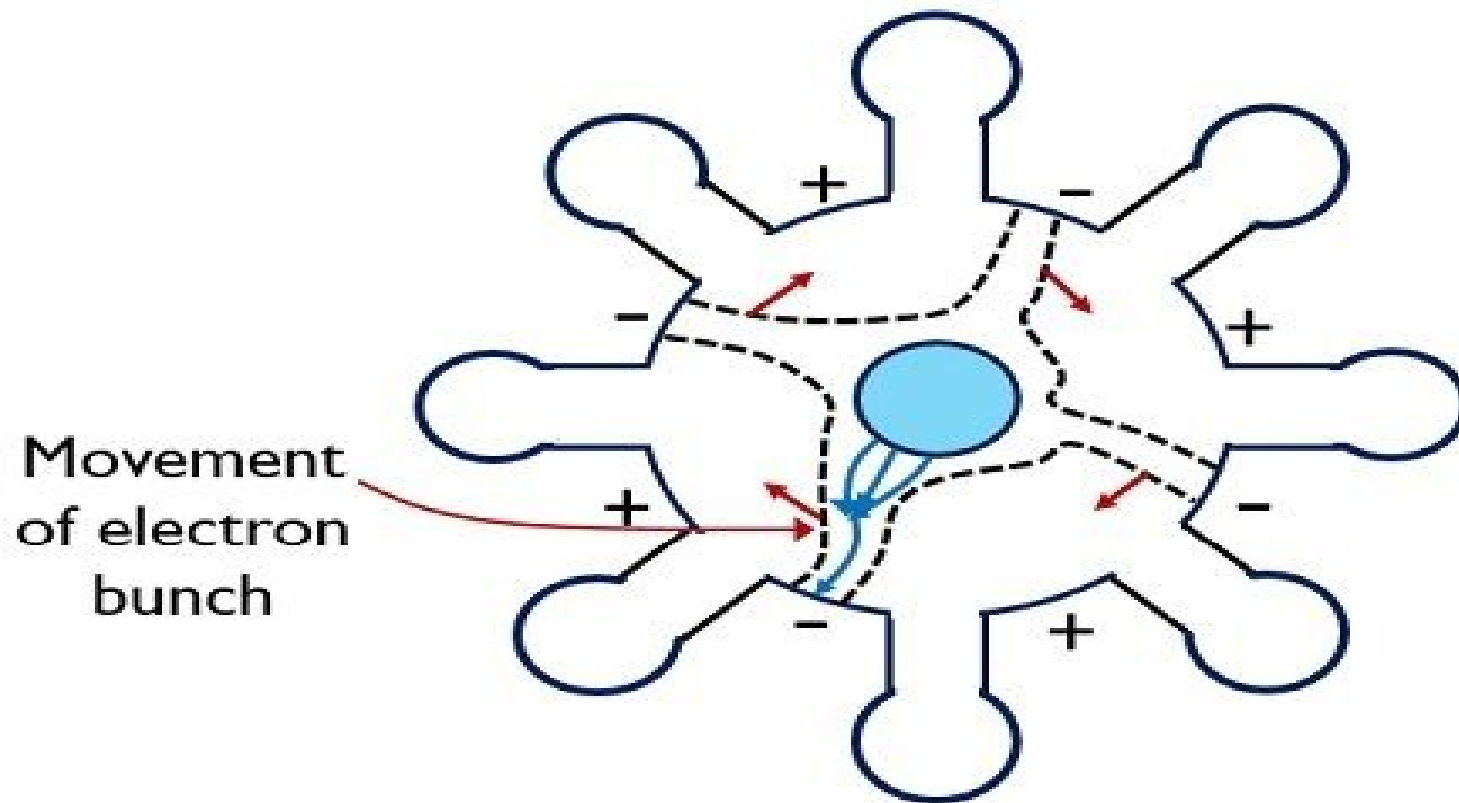


When moving electron takes energy from the oscillations

Electronics Desk

- **Case II:** Another condition arises in the presence of RF input. In this case, the emitted electron from the cathode while travelling takes energy from the oscillations thereby resultantly increasing its velocity.
- So despite reaching the anode, the electrons will bounce back to the cathode and these electrons are known as un-favored electrons.

- **Case III:** When the RF input is further increased then the electron emitted while travelling increases its velocity in order to catch up the electron emitted earlier with comparatively lower velocity.
- So, all those electrons that do not take energy from the oscillations for their movement are known as favored electrons. And these favored electrons form electron bunch or electron cloud and reaches anode from the cathode.
- The formation of electron bunch inside the tube is known as phase focusing effect.



**Path of electron cloud according to the rotation of spokes**

Electronics Desk

# Frequency Pushing and Pulling

- The variation in the oscillating frequency of the magnetron gives rise to the term frequency pushing and pulling.
- When the voltage applied at the anode of the magnetron is varied then this causes the variation in the velocity of the electrons moving from cathode to anode. This resultantly changes the frequency of oscillations.
- Therefore, we can say when the resonant frequency of the magnetron shows variation due to the change in the anode voltage then it is known as frequency pushing.

- The change in resonant frequency is sometimes a result of the change in the load impedance of the magnetron. The load impedance varies when the change is purely resistive or reactive. This frequency variation is known as frequency pulling. A steady power supply can provide a reduction in this frequency variation.

# Advantages

- Magnetrons are a highly efficient device used for generation of the high power microwave signal.
- The use of magnetrons in radar can produce radar system of better quality for tracking purpose.
- It is usually small in size thus less bulky.

# Disadvantages

- It is quite expensive.
- Despite producing a wide range of frequency, there exists a drawback in controllability of the generated frequency.
- It offers average power of around 1 to 2 kilowatts.
- Magnetrons are quite noisy.

# Applications of Magnetron

- A major application of magnetron is present in a pulsed radar system in order to produce a high-power microwave signal.
- Magnetrons are also used in heating appliances like microwave ovens so as to produce fixed frequency oscillations.
- Tunable magnetrons find their applications in sweep oscillators.

- It is noteworthy here that this mode of operation of the magnetron is also known as “ **$\pi$  mode**”. This is so because a proper phase shift of  **$180^\circ$**  is maintained between two adjacent plates. Also, it is to be noted that oscillations are **only built-up in  $\pi$  mode**.

